

# DUO-TOUCH® SG Series Two-Hand Control Module AT-GM-13A and AT-HM-13A



## Datasheet

Models AT-GM-13A and AT-HM-13A, for use with two actuating devices

To view or download the latest technical information about this product, including specifications, dimensions, accessories, and wiring, see [www.bannerengineering.com](http://www.bannerengineering.com). The AT-GM-13A and AT-HM-13A models are for sale and use as replacement devices only. They are not intended for new installations.

## Features

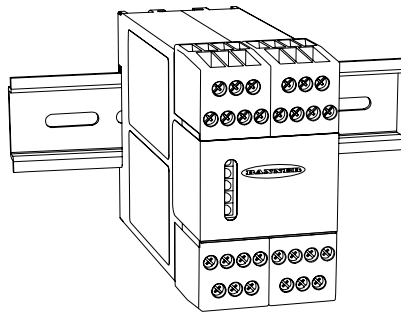

- Diverse-redundant microcontrollers
- Supplies power and monitors two Banner STB Self-Checking Optical Touch Buttons, or two mechanical push buttons
- Four redundant, forced-guided (mechanically linked) output contacts rated at 6 A
- Two auxiliary solid-state outputs (NPN and PNP), plus auxiliary N.C. relay output
- Feedback input monitors external machine control elements
- Five indicator LEDs for Power, Fault, Input 1, Input 2, and Output
- 24V dc plus 115V ac or 230V ac operation, depending on model
- DIN-rail-mountable 45 mm-wide housing with removable terminal blocks
- 500 ms (max.) simultaneity requirement for touch-/push-button operation

## Overview

A DUO-TOUCH SG Two-Hand Control Safety Module may be used with:

- Two Banner STB Self-Checking Optical Touch Buttons, each with one normally open and one normally closed relay output contact, or
- Two Banner STB Self-Checking Optical Touch Buttons, each with two current-sourcing PNP outputs, or
- Two mechanical push buttons with one normally open and one normally closed contact each (Form C contact)

If the machine operator removes one or both hands from the actuating device(s), the Duo-Touch SG relays de-energize, causing the output contacts to open. The relays will not re-energize until both actuating devices are deactivated and then simultaneously reactivated.

The Duo-Touch SG Two-Hand Control Kit system has been designed to meet:

- Type IIC requirements of EN 574 Safety of Machinery – Two-Hand Control Devices, and
- Category 4 requirements of EN 954-1 Safety of Machinery – Safety-Related Parts of Control Systems – Part 1: General Principles of Design

The Safety Module's output signal consists of four sets of redundant, forced-guided (mechanically linked) contacts (see [Electrical Installation](#) on page 6). Circuitry within the Safety Module monitors these internal contacts and prevents an output signal from occurring if a fault is detected. A feedback loop is offered for monitoring the status of the machine control elements.

DUO-TOUCH SG Safety Module LED Indicators (see Figure 1)

Power On:	ON when power is applied	Output Status:	ON if both relays (K1 and K2) are energized Flashing if feedback error has occurred
Fault:	ON if simultaneity is not met or external wiring fault Flashing when internal fault condition is detected	Input 1 (2) Status:	ON if touch button is activated OFF when button is not activated Flashing if external wiring fault is detected



### WARNING: Point-of-Operation Guarding

When properly installed, a two-hand control device provides protection only for the hands of the machine operator. It may be necessary to install **additional** safeguarding, such as safety light screens, additional two-hand controls, and/or hard guards, to protect all individuals from hazardous machinery.

Failure to properly guard hazardous machinery can result in a dangerous **condition** which could lead to serious injury or death.



## Theory of Operation

The input circuit of the DUO-TOUCH SG Safety Module requires simultaneous actuation (within 0.5 seconds of each other) of both two-hand control actuators to generate an output signal.

The timing diagram illustrates that an output signal from the DUO-TOUCH SG Safety Module occurs only if switch #1 (SW1) and switch #2 (SW2) are actuated within 0.5 seconds of each other. The output signal drops within 35 milliseconds following the release of either switch. The device output does not re-energize until both hand controls are disengaged, and then simultaneously re-actuated. This logic reduces the possibility of defeating the two-hand control by tying down one or both hand controls.

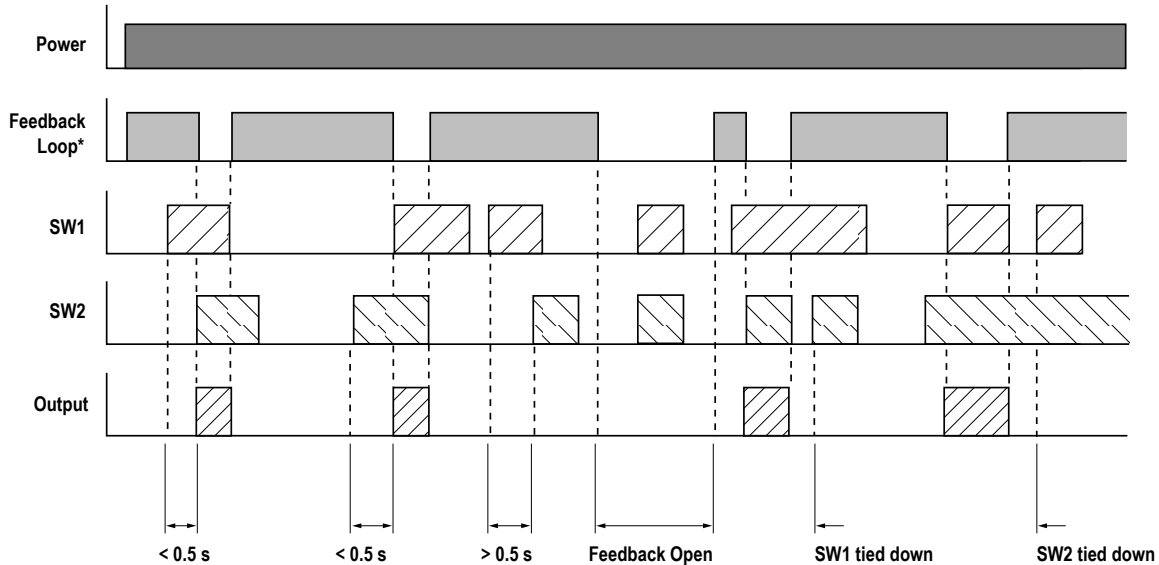

Figure 1. DUO-TOUCH SG Safety Module AT-xM-13A timing diagram

\* Feedback loop can remain closed at all times (if jumpered), when no monitoring contacts are available.

## Appropriate Applications

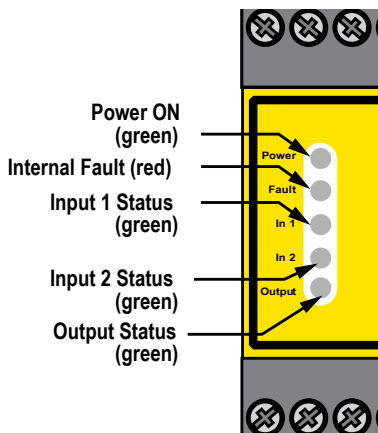

Figure 2. AT-xM-13A Status Indicators

The DUO-TOUCH SG Two-Hand Control Safety Module may be used as an initiation device for most powered machinery when machine cycling is controlled by a machine operator.

Using a two-hand control system makes the operator a “hostage” while the hazard is present, thus limiting or preventing exposure of that operator to the hazard. The two-hand control actuators must be located in a way that hazardous motion is completed or stopped before the operator can release one or both of the buttons and reach the hazard (see Separation Distance).

Simultaneous use of both hands is required, meaning that both buttons must be actuated within a very short time span. The time span is specified by ANSI/RIA R15.06, ANSI/NFPA79, and EN 574 as not more than 500 ms, even under single-fault conditions. This requirement reduces the possibility of intentional defeat and unintended initiation of the machine cycle.

When used in single-cycle or single-stroke mode, the machine control must provide an anti-repeat feature so that the operator must release the two-hand control actuators after each machine cycle, before a new cycle can be initiated.



**CAUTION:** Not an **Anti-Repeat** Control Device

**Anti-repeat** control is not a **function** of this Two-Hand Control Safety Module. The user of this device must provide a suitable means of accomplishing anti-repeat control for any single-stroke or single-cycle machine.

The actuating devices must be protected from accidental or unintended operation. This can be accomplished by their mounting position and/or through the use of protective shields such as rings, guards or shields; see [Figure 3](#) on page 4 and [Figure 4](#) on page 4.



Note: Two-hand control and two-hand trip safeguarding protect *only the operator's hands*. Additional safeguarding may be required. The user must refer to the relevant standards for additional requirements for the application of two-hand control and two-hand trip devices when used for safeguarding.

## Part-Revolution Clutched Machinery

A two-hand control safety module can be used for the following functions: inch (jog), single-stroke, or continuous (run). Two-hand control safety modules are recognized as a means of protecting the machine operator when the hand controls are safely located and protected from false operation (see Mechanical Installation and Separation Distance) and when properly interfaced to the machine (see Electrical Installation) to control the required stopping action.

## Full-Revolution Clutched Machinery

A two-hand control safety module used to initiate the cycle of a full-revolution clutched machine is known as a two-hand trip device.

Two-hand trip devices are recognized as a means of protecting the machine operator when the hand controls are safely located and protected from false operation (see Mechanical Installation and Separation Distance) and when properly interfaced to the machine (see Electrical Installation) to prevent accidental cycle initiation.

## Important . . . Read This Before Proceeding!

---

In the United States, the functions that the Banner DUO-TOUCH Two-Hand Control Module is intended to perform are regulated by the Occupational Safety and Health Administration (OSHA). Whether or not any particular DUO-TOUCH Two-Hand Control Module installation meets all applicable OSHA requirements depends upon factors that are beyond the control of Banner Engineering Corp. These factors include the specific ways the safety module is applied, installed, wired, operated, and maintained.

Banner Engineering Corp. has attempted to provide complete application, installation, operation, and maintenance instructions. In addition, we suggest that any questions regarding the use or installation of this two-hand control safety system be directed to the factory applications department at the telephone numbers or address shown on the back cover of this manual.

The user of this Two-Hand Control safety module must ensure that all machine operators, maintenance personnel, electricians, and supervisors are thoroughly familiar with and understand all instructions regarding the installation, maintenance, and use of this system, and with the machinery upon which it is installed.

The user and any personnel involved with the installation and use of this safety module must be thoroughly familiar with all applicable OSHA regulations and ANSI standards. The regulations and standards, listed below, directly address the use of two-hand control systems. Banner Engineering Corp. makes no claim regarding a specific recommendation of any organization, the accuracy or effectiveness of any information provided, or the appropriateness of the provided information for a specific application.

The user has the responsibility to ensure that all local, state, and national laws, rules, codes, and regulations relating to the use of this Two-Hand Control module are satisfied. Extreme care is urged that all legal requirements are met and that all installation and maintenance instructions contained in this manual are followed.

## U.S. Application Standards

ANSI B11.0 Safety of Machinery: General Requirements and Risk Assessment  
ANSI NFPA 79 Electrical Standard for Industrial Machinery  
ANSI/RIA R15.06 Safety Requirements for Industrial Robots and Robot Systems

## International/European Standards

ISO TR12100-1 & -2 (EN 292-1 & -2) Safety of Machinery – Basic Concepts, General Principles for Design  
EN 60204-1 Electrical Equipment of Machines Part 1: General Requirements  
EN 954-1 Safety-Related Parts of Control Systems  
EN 13855 (EN 999) The Positioning of Protective Equipment in Respect to Approach Speeds of Parts of the Human Body  
EN 574 Two-Hand Control Devices – Functional Aspects – Principles for Design (also request a type "C" standard for your specific machinery.)

## Sources of Standards and Regulations

OSHA Documents: [www.osha.gov](http://www.osha.gov) (Tel: 202-512-1800)  
American **National Standards Institute** (ANSI): [www.ansi.org](http://www.ansi.org) (Tel: 212-642-4900)  
**Robotics Industries Association** (RIA): [www.robotics.org](http://www.robotics.org) (Tel: 734-994-6088)  
**National Fire Protection Association** (NFPA): [www.nfpa.org](http://www.nfpa.org) (Tel: 800-344-3555)  
NSSN **National Resource for Global Standards** : [www.nssn.org](http://www.nssn.org) (Tel: 212-642-4980)  
IHS Standards Store: [www.global.ihs.com](http://www.global.ihs.com) (Tel: 303-397-7956, 800-854-7179)  
Document Center: [www.document-center.com/home.cfm](http://www.document-center.com/home.cfm) (Tel: 650-591-7600)

## Installation Instructions

### Mechanical Installation

The Module must be installed inside a NEMA 3 (IP54) rated, or better, enclosure. It is not designed for exposed wiring. See [Dimensions](#) on page 11 for Safety Module Dimensions. The device mounts directly onto a standard 35 mm DIN rail.



#### CAUTION: Hand Controls

The environment in which hand controls are installed must not adversely **affect** the means of **actuation**. Severe contamination or other environmental influences may cause slow response or false On conditions of mechanical or ergonomic buttons. This may result in exposure to a hazard.

### Heat Dissipation Considerations

For reliable operation, ensure that the operating specifications are not exceeded. The enclosure must provide adequate heat dissipation, so that the air closely surrounding the Module does not exceed the maximum operating temperature stated in the Specifications. Methods to reduce heat build-up include venting, forced airflow (for example, exhaust fans), adequate enclosure exterior surface area, and spacing between modules and other sources of heat.

### Installation of Hand Controls

Each actuating device typically requires a normally open and a normally closed (for example, Form C or SPDT) hard contacts, each capable of reliably conducting 20 mA at 12 V dc. For complementary PNP operation, model STBVP.. touch buttons must be used to ensure proper functionality.

Standards require that the actuating devices be mounted to protect them from accidental or unintentional operation. Use shields, covers, rings, collars, dividers, or similar protection to prevent accidental switch actuation and to discourage use of forearms or elbows. European standard EN 574 includes a detailed discussion of approaches to protection of hand controls.

The hand controls must be arranged far enough apart so that the operator cannot operate both hand controls by the use of one arm. Typically, this distance is not less than 550 mm (21.7 in) in a straight line, but using guards or alternate mounting arrangement can allow shorter distances, per EN 574. This standard also recommends that the hand controls be arranged on a horizontal (or nearly horizontal) surface that is 1,100 mm (43.3 in) above the floor.

Ergonomic principles should be considered to avoid unnecessary fatigue in the installation of the hand controls. See EN 574 Two-Hand Control, ANSI B11.TR1–Ergonomic Guidelines, and EN 894–Safety of Machinery–Ergonomic Requirements–Control Actuators for further information.

The figures show two examples for mounting Banner's STB Touch Buttons. When mounted on top of the control bar, the protective field covers should be in place, as shown. For added protection, mount the devices sideways under and behind a protective hood, rather than on top of the bar, leaving the field covers off. This side mount reduces the possibility of the operator easily positioning and leaving an object in the path of the beam, intentionally bypassing the safeguard.

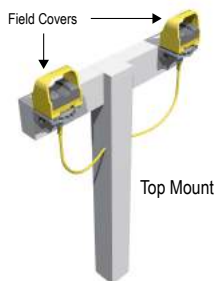

Figure 3. Install activation devices so that they are protected to prevent defeat or inadvertent actuation (STB Touch Buttons shown)



Figure 4. Mount devices sideways under a protective hood for added protection (STB Touch Buttons shown)



#### CAUTION: Install Hand Controls to Prevent Accidental **Actuation**

Total protection for the two-hand control system from defeat is not possible. However, the user is required by U.S. and **International** standards to arrange and protect hand controls to minimize the possibility of defeat or accidental **actuation**.

### Requirements for **Multiple-Operator** Control

Standards have specified several conditions for situations where multiple operators work together to control one machine:

- Each operator must actuate his/her own pair of actuating devices, with all pairs of actuators active at one time, in order to initiate a machine cycle; the machine may not be allowed to operate until this condition is true

- The actuators all must be released between cycles
- The actuation and de-actuation of all workstations requiring two-hand control must be supervisable and must provide indication
- The clutch/brake control system must be designed so that the clutch cannot be actuated if all the operating workstations are bypassed

It is the user's responsibility to determine if this two-hand control system can be interfaced to the machine in a manner to **satisfy all existing** requirements for **multiple-operator** control.

## Two-Hand Control Safety Distance (Minimum Distance)



### WARNING: Location of Touch Button Controls

Hand controls must be mounted a safe distance from moving machine parts, as determined by the appropriate standard. It must not be possible for the operator or other non-qualified persons to relocate them. Failure to establish and maintain the required safety distance may result in serious injury or death.

### U.S. Applications

The Safety Distance formula, as provided in ANSI B11.19:

**Part-Revolution Clutch Machinery** (the machine and its controls allow the machine to stop motion during the hazardous portion of the machine cycle)

$$D_S = K \times (T_S + T_R + T_H)$$

For **Full-Revolution Clutch Machinery** (the machine and its controls are designed to complete a full machine cycle)

$$D_S = K \times (T_M + T_R + T_H)$$

$D_S$

the Safety Distance (in inches)

$K$

the OSHA/ANSI recommended hand-speed constant (in inches per second), in most cases is calculated at 63 in/sec, but may vary between 63 in/sec to 100 in/sec based on the application circumstances;

not a conclusive determination; consider all factors, including the physical ability of the operator, when determining the value of  $K$  to be used

$T_H$

the response time of the slowest hand control from the time when a hand disengages that control until the switch opens;

$T_H$  is usually insignificant for purely mechanical switches. However,  $T_H$  should be considered for safety distance calculation when using electronic or electromechanical (powered) hand controls. For Banner Self-checking Touch Buttons (STBs) the response time is 0.02 seconds

$T_M$

the maximum time (in seconds) the machine takes to cease all motion after it has been tripped. For full revolution clutch presses with only one engaging point,  $T_M$  is equal to the time necessary for one and one-half revolutions of the crankshaft. For full revolution clutch presses with more than one engaging point,  $T_M$  is calculated as follows:

$$T_M = (1/2 + 1/N) \times T_{CY}$$

$N$  = number of clutch engaging points per revolution

$T_{CY}$  = time (in seconds) necessary to complete one revolution of the crankshaft

$T_R$

the response time of the Safety Controller as measured from the time a stop signal from either hand control. The Safety Controller response time is obtained from the Configuration Summary in the PC Interface.

$T_S$

the overall stop time of the machine (in seconds) from the initial stop signal to the final ceasing of all motion, including stop times of all relevant control elements and measured at maximum machine velocity

$T_S$  is usually measured by a stop-time measuring device. If the specified machine stop time is used, add at least 20% as a safety factor to account for brake system deterioration. If the stop-time of the two redundant machine control elements is unequal, the slower of the two times must be used for calculating the separation distance

### European Applications

The Minimum Distance Formula, as provided in EN 13855:

$$S = (K \times T) + C$$

European **Applications**

- S  
the Minimum Distance (in millimeters)
- K  
the EN 13855 recommended hand-speed constant (in millimeters per second), in most cases is calculated at 1600 mm/sec, but may vary between 1600 to 2500 mm/sec based on the application circumstances;  
not a conclusive determination; consider all factors, including the physical ability of the operator, when determining the value of K to be used.
- T  
the overall machine stopping response time (in seconds), from the physical initiation of the safety device to the final ceasing of all motion
- C  
the added distance due to the depth penetration factor equals 250 mm, per EN 13855. The EN 13855 C factor may be reduced to 0 if the risk of encroachment is eliminated, but the safety distance must always be 100 mm or greater

**Example Safety Distance ( $D_s$ ) Calculation**

The following example illustrates the use of the formula to calculate the safety distance for a part-revolution clutch machine. This example uses 0.50 seconds as a typical value for  $T_s$  and 0.02 seconds for  $T_h$ :

$$\begin{aligned}
 K &= 63 \text{ in per second} \\
 T_s &= 0.50 \text{ seconds (measured by a stop-time measuring device)} \\
 T_r &= 0.035 \text{ seconds} \\
 T_h &= 0.02 \text{ seconds (STB response time, for this example)} \\
 D_s &= K \times (T_s + T_r + T_h) \\
 &= 63 \text{ in } (0.50 + 0.035 + 0.02) \\
 &= 35 \text{ in}
 \end{aligned}$$

In this example, both hand controls must be located no closer than 36" from the nearest hazard point.

**Electrical Installation**

Because the DUO-TOUCH SG Safety Module interfaces to many types of machine controls, it is not possible to give exact wiring instructions here. The following guidelines are general in nature.

**CAUTION: Disconnect Power Before Wiring**

Before making any wire **connections**, make certain all power is disconnected from the Safety Module and the machine to be controlled.

Electrical installation of hand controls, the DUO-TOUCH Safety Module, and the interconnection to the machine control must be made by qualified personnel and must comply with NEC (National Electrical Code), ANSI/NFPA79 or IEC60204-1, and all applicable local standards.

Dangerous voltages may be present along the Safety Module wiring barriers whenever power to the machine control elements is On. Exercise extreme **caution** whenever machine control power is or may be present. Always disconnect power to the machine control elements before opening the enclosure housing of the Safety Module.

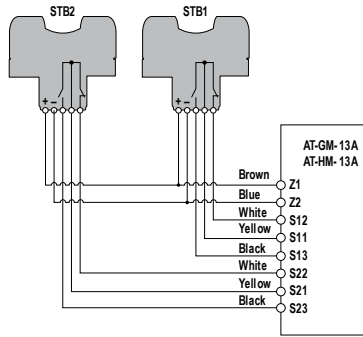

Figure 5. Hookup to two STB touch buttons with contact outputs

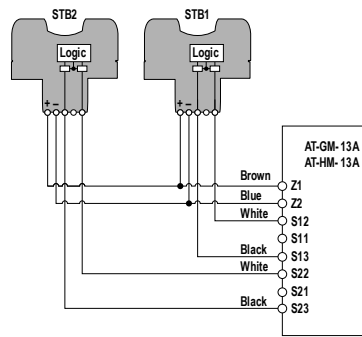

Figure 6. Hookup to two STB touch buttons with PNP (sourcing) outputs

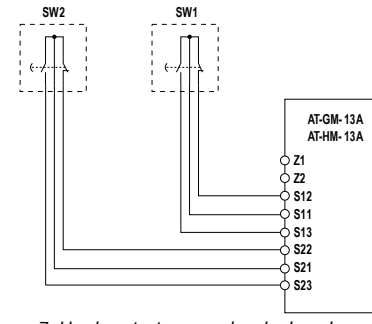

Figure 7. Hookup to two mechanical push buttons with contact outputs

### Connection of Input Switches

The actuation devices are connected to the DUO-TOUCH SG module as shown in Figures 5, 6, and 7. SW1 and SW2 must both have normally open and normally closed output contacts, or two current-sourcing complementary outputs each, all capable of reliably switching up to 20 mA, at 12V dc. If hand controls have metal housings, the housings must be connected to protective earth ground.

If STB Touch Buttons are used, connect the brown and blue wires to terminals Z1 and Z2. Electronic actuation devices, including STB Touch Buttons, must use terminals Z1 and Z2 for supply voltage.



#### WARNING: Use of Electronic Hand Controls

Electronic (powered) hand controls include optical touch buttons, capacitive touch buttons and similar devices. When electronic hand controls are used as input switches for a Safety Module, the hand controls and the Safety Module must be powered from the same voltage source. Failure to do so creates a **potentially dangerous condition**, which may result in serious injury or death.

If power is applied to the Safety Module before power is applied to the electronic hand controls, an output from the Safety Module could result and may trigger machine motion. Also, electronic hand controls cannot guarantee the state of their outputs at the time power is applied to them.

### Connection of Power to the DUO-TOUCH SG Safety Module

The Safety Module requires a 24V dc, 115V ac or 230V ac supply voltage (see [AT-xM-13A Specifications](#)). Use extreme caution whenever installing ac power. Use a minimum of 16 to 18 AWG wire for power and output connections. A hand-operated supply disconnect (e.g. a circuit breaker) must be provided (per NFPA79 and IEC/EN60204).

### Connection to the Machine to be Controlled



#### WARNING: Interfacing Safety Outputs

NEVER wire or interface an intermediate device (for example, PLC, PES, PC) that can fail in such a manner that there is a loss of the safety stop command to the MPCEs.

Doing so may result in serious bodily injury or death.

Figure 8 shows a generic connection of the Safety Module's two redundant output contacts to machine primary control elements MPCE1 through MPCE4. An MPCE is defined as an electrically-powered element, external to the safety module, which directly controls the machine's normal operating motion so that it is the last (in time) to operate when motion is either initiated or arrested. Some older machines offer only one MPCE; for such machines, it may be necessary to add a second MPCE to establish the appropriate level of safety integrity (e.g., control reliability).

The connection of the safety outputs must be in such a manner that the stop command issued by the AT-xM-13A can not be overridden by a device or circuit that is not at the same level of safety integrity. This means that the safety outputs are interfaced on the output of the machine logic (e.g., PLC or PC). Then, normally, a feedback signal identifies to the machine logic the status of the safety module and, if possible, the status of the MPCEs. If interposing relays are used, they must be of mechanically linked (forced-guided) design and monitored by the MPCE Monitoring Circuit (Y1/Y2).

As a summary, Control Reliability (OSHA 29CFR1910.217, ANSI B11, and ANSI/RIA R15.06) and Category 3 and 4 (ISO13849-1) requirements demand that a single failure does not lead to the loss of the safety function, or does not prevent a normal or immediate stop from occurring. The failure or the fault must be detected at or before the next demand of safety (e.g., at the beginning or end of a cycle, or when a safeguard is actuated). The safety-related function of the machine control then must issue an immediate stop command or prevent the next machine cycle or hazardous situation until the failure or fault is corrected. The user must refer to the relevant standard(s) for complete **information**.

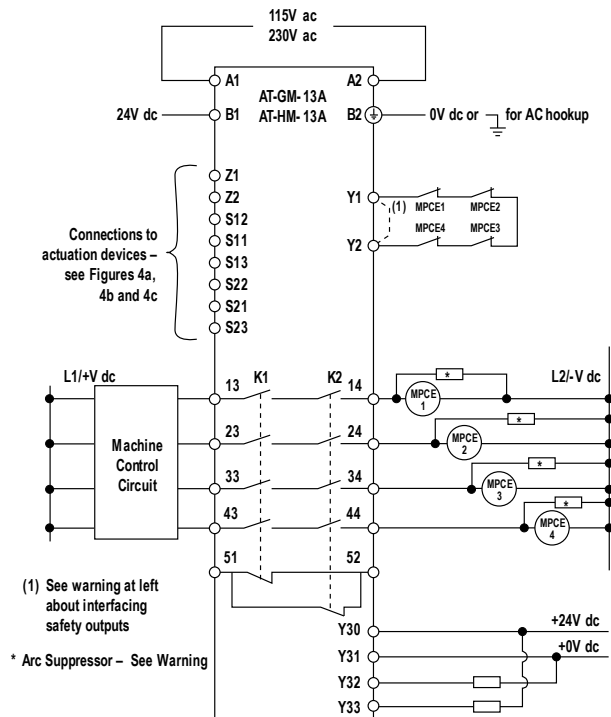

Figure 8. Machine control circuit connections

As shown in Figure 8, a normally-closed, mechanically linked monitor contact from each of the four MPCEs must be connected in series across terminals Y1 and Y2. This allows the Safety Module to monitor the state of the MPCEs, and to prevent a successive machine cycle, if an MPCE fault is detected. Monitoring MPCE contacts is one method of maintaining control reliability. When MPCE monitor contacts are not available, a jumper wire must be installed across terminals Y1 and Y2.

When a jumper wire is used (dotted line between Y1 and Y2 in Figure 8), it is the user's responsibility to provide an appropriate level of safety for the means of machine interfacing to ensure that any single MPCE component failure will not result in the loss of safety.



#### WARNING: Use of Arc Suppressors

If arc suppressors are used, they **MUST** be installed as shown across the coils of the Machine Primary Control Elements (MPCEs). NEVER install suppressors directly across the output contacts of the Safety Module. It is possible for suppressors to fail as a short circuit. If installed directly across the output contacts of the Safety Module, a short-circuited suppressor creates an unsafe **condition** which may result in serious injury or death.

When switching inductive ac loads, it is good practice to protect the Safety Module outputs by installing appropriately-sized arc suppressors. However, if arc suppressors are used, they must be installed across the load being switched (e. g., across the coils of external safety relays), and never across the Safety Module's output contacts.

## System Checkout

### Initial Checkout Procedure



#### CAUTION: Disconnect Power Prior to Checkout

Before performing the **initial** checkout procedure, make certain all power is disconnected from the machine to be controlled.

Dangerous voltages may be present along the Safety Module wiring barriers whenever power to the machine control elements is On. Exercise extreme **caution** whenever machine control power is or may be present. Always disconnect power to the machine control elements before opening the enclosure housing of the Safety Module.

Temporarily disconnect the wires connected to the outputs of the DUO-TOUCH SG Safety Module at terminals 13/14, 23/24, 33/34, 43/44, Y32, and Y33.



**WARNING: Do Not Use System Until Checkouts Are Verified**

If all of the described checks cannot be **verified**, do not **attempt** to use the two-hand control safety system **until** the defect or problem has been corrected. **Attempts** to use the guarded machine under such **conditions** may result in serious bodily injury or death.

To perform the initial checkout, it is necessary to view the red Fault LED and the four green Status indicators: Power, Input 1, Input 2 and Output. Proceed with caution around open wiring.

1. Verify that the two actuating devices are properly connected to the DUO-TOUCH SG Safety Module.
2. Apply power to the Safety Module and to the actuating devices, if applicable.
3. Verify that only the Power indicator is ON. If any of the other Safety Module indicators are ON, disconnect the power to the Safety Module and check all wiring. Do not **continue** this checkout procedure **until** the cause of the problem is corrected.
4. Activate both hand controls simultaneously (within 0.5 seconds), and hold them engaged. Input 1 and Input 2 indicators should come ON. Release both hand controls simultaneously. Output indicators should go OFF.
5. Again, activate the two hand controls simultaneously, and hold them engaged. Input 1, Input 2, and Output indicators should come ON. Release one hand control, while holding the other engaged. One of the Input indicators should remain ON. The Output indicator should go OFF. Re-activate the hand control which was just released. The Output indicator should remain OFF. Release both hand controls. Input 1 and Input 2 indicators should then be OFF.
6. Activate only one hand control and hold it engaged. Input 1 (or Input 2) indicator should come ON. After more than 1/2 second, activate the second hand control. Input 1 and 2 indicators should remain ON, while Output indicator remains OFF.
7. Remove power from the Safety Module and disconnect the monitor contact feedback loop at terminals Y1 and/or Y2. Re-apply power to the Safety Module. Activate both hand controls simultaneously. Output indicator LED should remain OFF.

If the DUO-TOUCH SG Safety Module passes all of these tests, reconnect the output wires at terminals 13/14, 23/24, 33/34 and 43/44, and the monitor contact feedback loop at terminals Y1 and Y2. Do not **attempt** to use the DUO-TOUCH SG Two-Hand Control Safety Module **until** all of the tests are passed.

Perform the Daily Checkout procedure to verify proper operation.

## Daily Checkout

To be performed at every power-up, shift change, and machine setup change.

Daily checkout and checkouts after tooling and machine setup changes must be performed by a Designated Person, appointed and identified in writing by the employer.

**WARNING: Do Not Use System Until Checkouts Are Verified**

If all of the described checks cannot be **verified**, do not **attempt** to use the two-hand control safety system **until** the defect or problem has been corrected. **Attempts** to use the guarded machine under such **conditions** may result in serious bodily injury or death.

1. Verify that all point-of-operation guards are in place and operating properly.
2. Verify that the two actuating devices must be simultaneously engaged to actuate the machine.
3. For single-cycle machines: Verify that maintained engagement of the two actuating devices results in only one machine cycle.
4. For **part-revolution** clutch machinery: Verify that release of either actuating device results in the immediate arrest of the machine motion.
5. Verify that the distance from each actuating device to the closest hazard point is not less than the calculated separation (safety) distance (see Separation Distance).

## Semi-Annual Checkout

To be performed at six-month intervals.

**WARNING: Do Not Use System Until Checkouts Are Verified**

If all of the described checks cannot be **verified**, do not **attempt** to use the two-hand control safety system **until** the defect or problem has been corrected. **Attempts** to use the guarded machine under such **conditions** may result in serious bodily injury or death.

This semi-annual checkout must be performed by a Qualified Person<sup>¶</sup>. A copy of test results should be kept on or near the machine.

1. Perform the daily checkout procedure (see Daily Checkout).
2. Perform the initial checkout procedure (see Initial Checkout).
3. Calculate the separation distance (see Separation Distance), and verify that the actuating devices are far enough away from the nearest hazard point. Relocate the actuating devices, if necessary.
4. Verify that the actuating devices are positioned to require the use of both hands for operation, and are protected from false or inadvertent operation.

<sup>¶</sup> A person who, by possession of a recognized degree or certificate of professional training, or who, by extensive knowledge, training, and experience, has successfully demonstrated the ability to solve problems relating to the installation, maintenance and use of the DUO-TOUCH SG Two-Hand Control Safety System.

- Inspect the machine controls and the connections to the DUO-TOUCH SG Safety Module to ensure that wiring is correct, as described in [Electrical Installation](#), and that no modifications have been made which could adversely affect the System.

## Specifications

---

### Supply Voltage and Current

A1-A2: 115 V ac (AT-GM-13A) or 230 V ac (AT-HM-13A), +/- 15%; 50/60 Hz  
 B1-B2: 24V dc, +/- 15%, 10% maximum ripple

### Supply Protection Circuitry

Protected against transient voltages and reverse polarity

### Power Consumption

Approx. 4 W/7 VA

### Auxiliary Supply Voltage (for solid-state outputs)

24 V dc @ 1 A (applied between Y30 and Y31)

### Auxiliary Solid-State Output Current

500 mA max., short circuit protected (Y32 or Y31)

### Output Configuration

Outputs (K1 and K2): four redundant (total of eight) safety relay (forced-guided) contacts

#### Contact ratings:

Maximum voltage: 250 V ac or 250 V dc

Maximum current:

N.O. Safety Output: 6 A ac or dc (resistive load)

N.C. Auxiliary Output (51/52): 5 A ac or dc (resistive load)

Maximum power:

N.O. Safety Output: 1500 VA, 200 watts

N.C. Auxiliary Output (51/52): 1250 VA, 200 watts

Mechanical life: 50,000,000 operations

Electrical life: 150,000 cycles (typically @ 1.5 kVA switching power)

**NOTE:** Transient suppression is recommended when switching inductive loads. Install suppressors across load. Never install suppressors across output contacts (see Warning in [Electrical Installation](#) on page 6).

### Output Response Time

35 milliseconds maximum ON to OFF

### Input Requirements

Outputs from actuating devices must each be capable of switching up to 20 mA @ 12V dc

### Simultaneity Monitoring Period

≤ 500 milliseconds

### Z1/Z2 Courtesy Voltage

24 V dc @ 150 mA (for STB button power, separate from Auxiliary output, unregulated)

### Status Indicators

4 green LED indicators: Power ON, Input 1 energized, Input 2 energized, and Output

1 red LED indicator: Fault

### Housing

Polycarbonate. Rated NEMA 1 (IEC IP20)

### Mounting

Mounts to standard 35 mm DIN rail track. Safety Module must be installed inside an enclosure rated NEMA 3 (IEC IP54), or better.

### Vibration Resistance

10 to 55 Hz @ 0.35 mm displacement per IEC 68-2-6

### Operating Conditions

0° to +50°C (+32° to 122°F)

90% @ +50°C maximum relative humidity (non-condensing)

Heat **Dissipation Considerations:** See [Mechanical Installation](#) on page 4

### Safety Category

4 per EN 954-1; Type IIIC per EN 574

### Certifications



For sale and use as replacement devices only. The AT-GM-13A and AT-HM-13A models are not intended for new installations.

## Dimensions

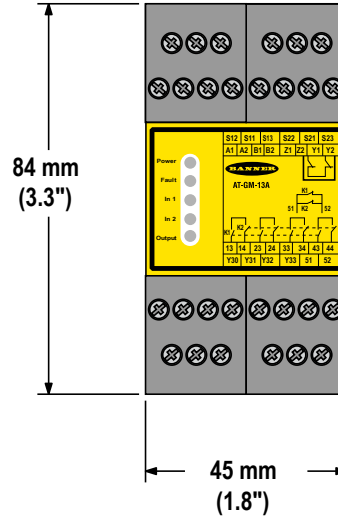
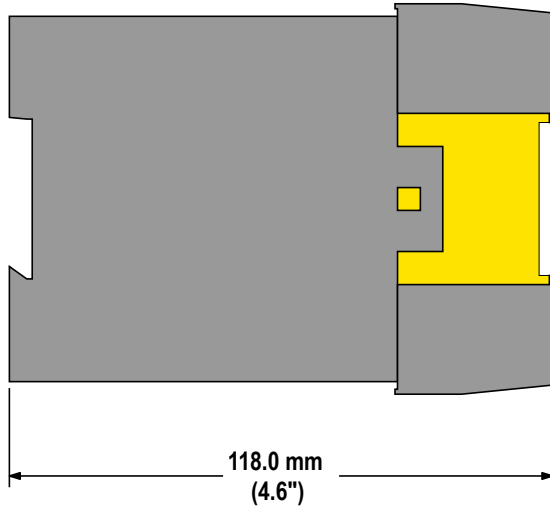

## Repairs



### CAUTION: Abuse of Module **After** Failure

If an internal fault has occurred and the Module will not reset, do not tap, strike, or otherwise **attempt** to correct the fault by a physical impact to the housing. An internal relay may have failed in such a manner that its replacement is required.

If the Module is not immediately replaced or repaired, **multiple** simultaneous failures may accumulate such that the safety **function** can not be guaranteed.



Note: Do not **attempt** any repairs to the DUO-TOUCH SG Two-Hand Control Module. It contains no **field-replaceable** components. Return it to the factory for warranty repair or replacement.

If it ever becomes necessary to return a DUO-TOUCH SG Safety Module to the factory, please do the following:

1. Contact the Banner Factory Application Engineering Group at the address or at the numbers listed at [www.bannerengineering.com](http://www.bannerengineering.com). They will attempt to troubleshoot the system from your description of the problem. If they conclude that a component is defective, they will issue an RMA (Return Merchandise Authorization) number for your paperwork, and give you the proper shipping address.
2. Pack the component carefully. Damage which occurs in return shipping is not covered by warranty.

## Removal of Terminal Blocks

To remove a terminal block, insert a small screwdriver into the slot and pry to loosen.



Note: When reinserting the block, take care to slide the dovetail on the terminal block into the slot on the frame.

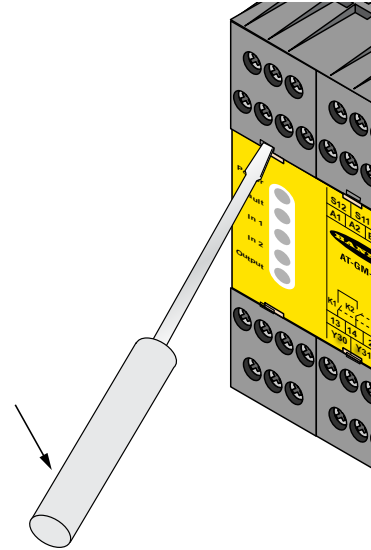

Figure 9. Removal of terminal blocks

## Banner Engineering Corp. Limited Warranty

Banner Engineering Corp. warrants its products to be free from defects in material and workmanship for one year following the date of shipment. Banner Engineering Corp. will repair or replace, free of charge, any product of its manufacture which, at the time it is returned to the factory, is found to have been defective during the warranty period. This warranty does not cover damage or liability for misuse, abuse, or the improper application or installation of the Banner product.

THIS LIMITED WARRANTY IS EXCLUSIVE AND IN LIEU OF ALL OTHER WARRANTIES WHETHER EXPRESS OR IMPLIED (INCLUDING, WITHOUT LIMITATION, ANY WARRANTY OF MERCHANTABILITY OR FITNESS FOR A PARTICULAR PURPOSE), AND WHETHER ARISING UNDER COURSE OF PERFORMANCE, COURSE OF DEALING OR TRADE USAGE.

This Warranty is exclusive and limited to repair or, at the discretion of Banner Engineering Corp., replacement. IN NO EVENT SHALL BANNER ENGINEERING CORP. BE LIABLE TO BUYER OR ANY OTHER PERSON OR ENTITY FOR ANY EXTRA COSTS, EXPENSES, LOSSES, LOSS OF PROFITS, OR ANY INCIDENTAL, CONSEQUENTIAL OR SPECIAL DAMAGES RESULTING FROM ANY PRODUCT DEFECT OR FROM THE USE OR INABILITY TO USE THE PRODUCT, WHETHER ARISING IN CONTRACT OR WARRANTY, STATUTE, TORT, STRICT LIABILITY, NEGLIGENCE, OR OTHERWISE.

Banner Engineering Corp. reserves the right to change, modify or improve the design of the product without assuming any obligations or liabilities relating to any product previously manufactured by Banner Engineering Corp. Any misuse, abuse, or improper application or installation of this product or use of the product for personal protection applications when the product is identified as not intended for such purposes will void the product warranty. Any modifications to this product without prior express approval by Banner Engineering Corp will void the product warranties. All specifications published in this document are subject to change; Banner reserves the right to modify product specifications or update documentation at any time. Specifications and product information in English supersede that which is provided in any other language. For the most recent version of any documentation, refer to: [www.bannerengineering.com](http://www.bannerengineering.com).