

WORLD-BEAM QS18 Expert with IO-Link

Instruction Manual

Original Instructions
196872 Rev. A
13 November 2018
© Banner Engineering Corp. All rights reserved



196872

Contents

1 Product Description	3
1.1 Models	3
1.2 Overview	4
2 Installation	5
2.1 Mount the Device	5
2.2 Wiring Diagrams	5
3 Sensor Configuration	6
3.1 IO-Link Interface	7
3.2 Push Button Enable/Disable	8
4 Select TEACH/SET Method	9
5 Configure TEACH/SET	10
6 TEACH/SET	12
7 Specifications	14
7.1 Dimensions	15
7.2 Performance Curves	15
8 Accessories	17
8.1 Cordsets	17
8.2 Retroreflectors	17
8.3 Brackets	18
9 Contact Us	20
10 Banner Engineering Corp. Limited Warranty	22

1 Product Description

Expert™ Sensor with IO-Link

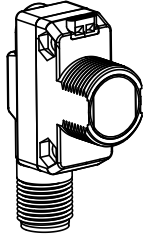

- IO-Link communication for sensor health monitoring and remote configuration
- Easy-to-use Expert-style Two-Point Static and Dynamic TEACH methods, plus Window, Light, and Dark SET, using IO-Link, push button or remote input
- Smart power-control algorithm to maximize performance in low-contrast applications
- Auto compensation algorithm provides long and reliable operation by compensating for dust build up and ambient temperature changes
- Fast response speed for high-speed applications
- User-selectable threshold offset percentage to optimize performance for the type of object being detected
- Easy configuration of the sensor by IO-Link, remote input or push button
- Convenient mounting options available for 18 mm barrel or side mount
- Bright indicator LEDs show operating status from 360°
- IEC IP67 rated ABS housing



WARNING: Not To Be Used for Personnel Protection

Never use this device as a sensing device for personnel protection. Doing so could lead to serious injury or death. This device does not include the self-checking redundant circuitry necessary to allow its use in personnel safety applications. A sensor failure or malfunction can cause either an energized or de-energized sensor output condition.

1.1 Models

Model ¹	Sensing Mode	Range	Output
QS18EK6LPQ8	 POLAR RETRO	3.5 m (12 ft) ²	IO-Link push/pull output and multi-function input/output
QS18EK6DQ8	 DIFFUSE	800 mm (31.5 in) ³	
QS18EK6DVQ8	 DIFFUSE	600 mm (23.6 in) ³	
QS18EKCV15Q8	 CONVERGENT VISIBLE RED	16 mm (0.65 in) ³	
QS18EK6CV45Q8		43 mm (1.7 in) ³	
QS18EK6FPQ8	 PLASTIC FIBER	Varies by mode and fiber optics used	

¹ 4-Pin M12/Euro-style integral quick disconnect models listed.

- To order the 150 mm (6 in) PVC cable model with a 4-pin M12/Euro-style quick disconnect, replace the suffix "Q8" with "Q5" in the model number. For example, QS18EK6LPQ5.
- To order the 4-in M8/Pico-style integral quick disconnect model, replace the suffix "Q8" with "Q7" in the model number. For example, QS18EK6LPQ7.
- To order the 4-pin M12/Euro-style quick disconnect model, replace the suffix "Q8" with "Q" in the model number. For example, QS18EK6LPQ.
- Models with a quick disconnect require a mating cordset.

² With the use of a BRT-84 reflector.

³ Based on 90% reflectance white test card.

1.2 Overview

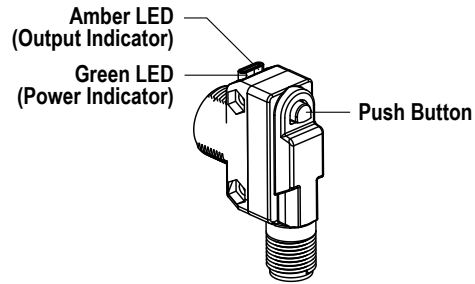

The Banner QS18E sensor is a high performance photoelectric sensor with IO-link and configurable multifunction input/output.

Indicators (Two LEDs: One Green, One Amber)		
Sensor Condition (Run Mode)	Green LED	Amber LED
Output OFF	ON	OFF
Output ON	ON	ON
Notification—Sensor needs to be reconfigured for reliable detection	Flashing	ON/OFF
Notification—Push button has been locked out	Flashes four times and returns to solid On after button press	ON/OFF

2 Installation

2.1 Mount the Device

1. If a bracket is needed, mount the device onto the bracket.
2. Mount the device (or the device and the bracket) to the machine or equipment at the desired location. Do not tighten the mounting screws at this time.
3. Check the device alignment.
4. Tighten the mounting screws to secure the device (or the device and the bracket) in the aligned position.

2.2 Wiring Diagrams

IO-Link with PNP Output (Factory Default)

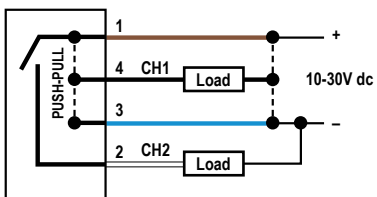

Figure 1. Channel 1 = IO-Link, Channel 2 = PNP Output

IO-Link with PNP Remote Input

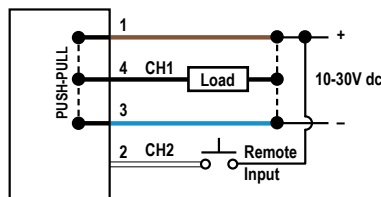

Figure 2. Channel 1 = IO-Link, Channel 2 = PNP Remote Input

Key

1. Brown
2. White
3. Blue
4. Black



Note: NPN/PNP and Remote Input configurations are programmable using IO-Link.



Note: Enable the remote input wire function using IO-Link. The default for the remote input wire function is Detection Output.

NPN Discrete Outputs

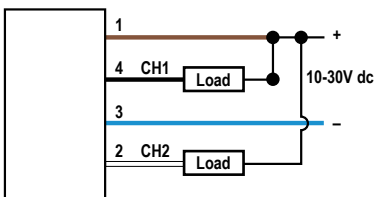

Figure 3. Channel 1 = NPN Output, Channel 2 = NPN Output

PNP Discrete Outputs

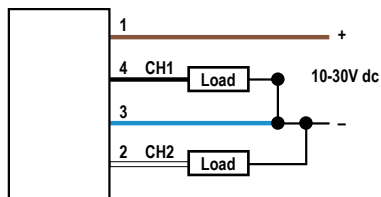

Figure 4. Channel 1 = PNP Output, Channel 2 = PNP Output

NPN Output and Remote Input

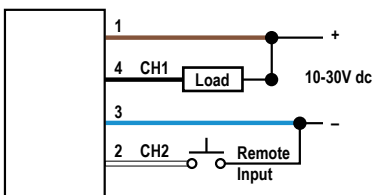

Figure 5. Channel 1 = NPN Output, Channel 2 = NPN Remote Input

PNP Output and Remote Input

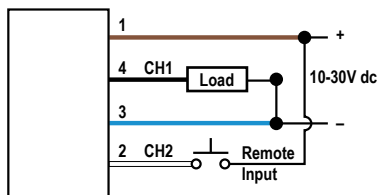

Figure 6. Channel 1 = PNP Output, Channel 2 = PNP Remote Input

3 Sensor Configuration

Configure the sensor using any of five TEACH or SET methods to define the sensing limits. Use the setup procedure to enable a 30 ms OFF-delay or to change the Light/Dark Operate setting. Sensing limit configuration options include:

- Two-Point Static TEACH: one switching threshold, determined by two taught conditions
- Dynamic TEACH: one switching threshold, determined by multiple sampled conditions
- Window SET: a sensing window, centered around a single sensing condition
- Light SET and Dark SET: One switching threshold, offset from a single sensing condition

The sensor's output is disabled during all TEACH and SET procedures, and is enabled upon return to Run mode.

Following any TEACH or SET procedure other than Two-Point Static TEACH, the Output ON condition (Light or Dark Operate setting) remains as it was last configured. To change that setting, or the OFF-delay setting, see [Figure 7](#) on page 7.

Push Button Configuration

Use the push button to configure the sensor. Click the push button according to the Input Flowchart, see [Figure 7](#) on page 7.

Remote Input Configuration

Enable the remote input wire using IO-Link. Use the remote input function to configure the sensor remotely. Connect the white wire of the sensor as shown in the wiring diagram. Pulse the remote line according to the Input Flowchart, see [Figure 7](#) on page 7.

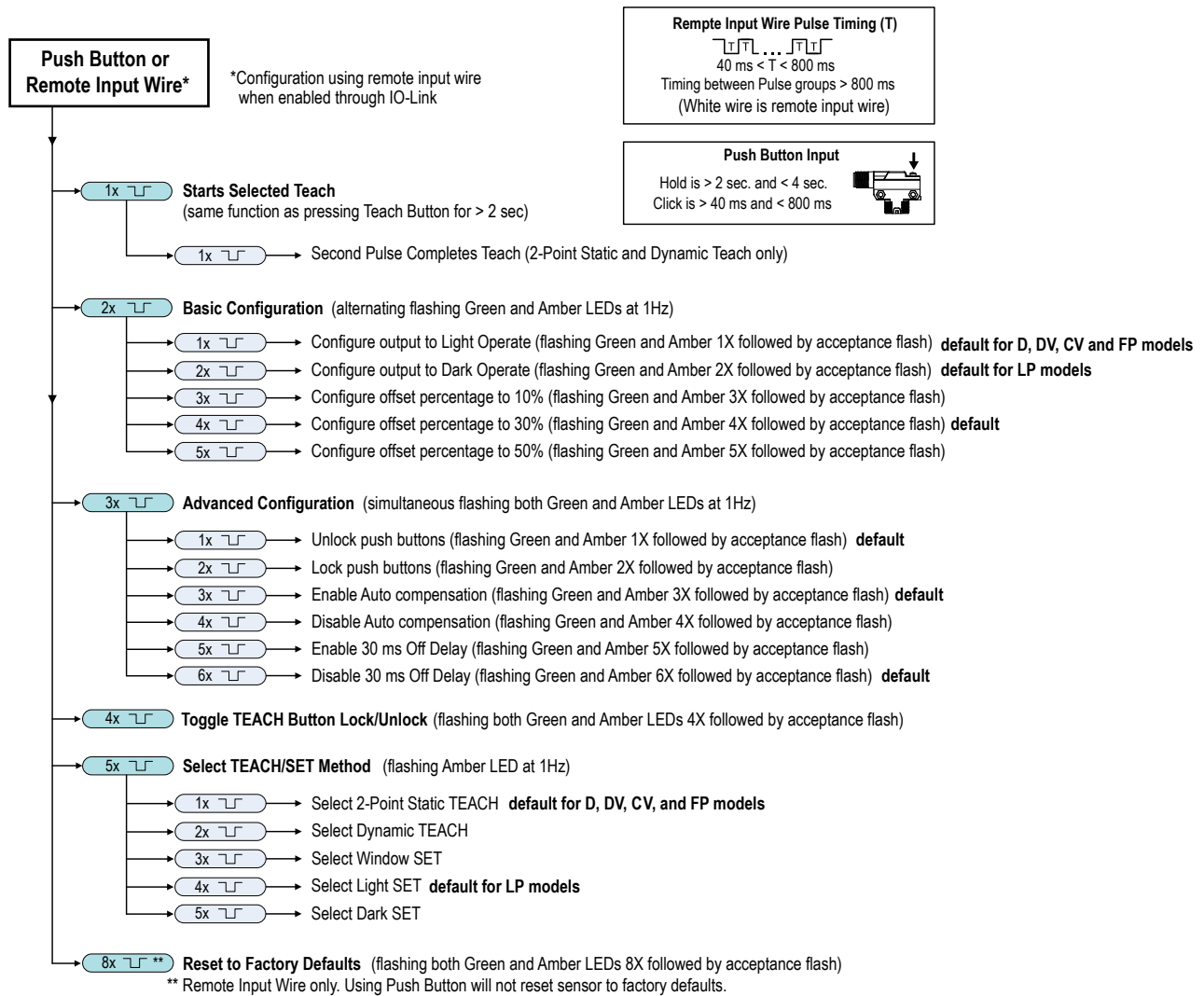

Note: Reconfiguration is required before a new TEACH/SET method takes effect.

Figure 7. Input Flowchart

3.1 IO-Link Interface

IO-Link is a point-to-point communication link between a master device and sensor. Use IO-Link to parameterize sensors and transmit process data automatically.

For the latest IO-Link protocol and specifications, see www.io-link.com.

Each IO-Link device has an IODD (IO Device Description) file that contains information about the manufacturer, article number, functionality etc. This information can be easily read and processed by the user. Each device can be unambiguously identified via the IODD as well as via an internal device ID. Download the QS18E's IO-Link IODD package (p/n 199851) from Banner Engineering's website at www.bannerengineering.com.

Banner has also developed Add On Instruction (AOI) files to simplify ease-of-use between the QS18E, multiple third-party vendors' IO-Link masters, and the Logix Designer software package for Rockwell Automation PLCs. Three types of AOI files for Rockwell Allen-Bradley PLCs are listed below. These files and more information can be found at www.bannerengineering.com.

Process Data AOIs—These files can be used alone, without the need for any other IO-Link AOIs. The job of a Process Data AOI is to intelligently parse out the Process Data word(s) in separate pieces of information. All that is required to make use of this AOI is an EtherNet/IP connection to the IO-Link Master and knowledge of where the Process Data registers are located for each port.



Parameter Data AOIs—These files require the use of an associated IO-Link Master AOI. The job of a Parameter Data AOI, when working in conjunction with the IO-Link Master AOI, is to provide quasi-realtime read/write access to all IO-Link parameter data in the sensor. Each Parameter Data AOI is specific to a given sensor or device.

IO-Link Master AOIs—These files require the use of one or more associated Parameter Data AOIs. The job of an IO-Link Master AOI is to translate the desired IO-Link read/write requests, made by the Parameter Data AOI, into the format a specific IO-Link Master requires. Each IO-Link Master AOI is customized for a given brand of IO-Link Master.

Add and configure the relevant Banner IO-Link Master AOI in your ladder logic program first; then add and configure Banner IO-Link Device AOIs as desired, linking them to the Master AOI as shown in the relevant AOI documentation.

3.2 Push Button Enable/Disable

The push button can be disabled to prevent unauthorized adjustment. Perform the appropriate procedure below to enable or disable the feature.

Method	Action		Result
Push Button—Disable	From Run mode, click the button three times, then click two times to disable the button.		Green and amber LEDs flash two times in unison followed by acceptance flash.
Push Button—Enable	From Run mode, click the button three times then click one time to enable the button.		Green and amber LEDs flash once in unison followed by acceptance flash.
Remote Input Wire—Disable/Enable	From Run mode, pulse the remote line four times.		Sensor toggles between enable/disable settings and returns to Run mode. Green and amber LEDs flash four times in unison followed by acceptance flash.

4 Select TEACH/SET Method

To select Light SET, Dark SET, Window SET, Two-Point Static TEACH, or Dynamic TEACH, follow these steps.

1. Initiate select TEACH/SET Method.

Method	Action	Result
Push Button	Click the button five times	The green LED turns off and the amber LED flashes at 1 Hz.
Remote Input	Pulse the remote input line five times	

2. Select TEACH/SET Method.

Method	TEACH/SET Method	Action	Result
Push Button	Two-Point Static TEACH	Click the button one time	The selected TEACH/SET method is enabled.
	Dynamic TEACH	Click the button two times	
	Window SET	Click the button three times	
	Light SET	Click the button four times	
	Dark SET	Click the button five times	
IO-Link	Two-Point Static TEACH	Set BDC1 Mode using IO-Link	
	Dynamic TEACH		
	Window SET		
	Light SET		
	Dark SET		
Remote Input	Two-Point Static TEACH	Pulse the remote line one time	
	Dynamic TEACH	Pulse the remote line two times	
	Window SET	Pulse the remote line three times	
	Light SET	Pulse the remote line four times	
	Dark SET	Pulse the remote line five times	

5 Configure TEACH/SET

By default, the sensor TEACH/SET method is Two-Point Static TEACH. To perform a TEACH/SET, use the following procedures for your preferred method.

Push Button

Action		Result
Two-Point Static TEACH	<ol style="list-style-type: none"> 1. Present the output ON target condition. 2. Press and hold the button for longer than 2 seconds to enter TEACH mode and configure the output ON light level. 3. Present the output OFF target condition. 4. Click the button once to configure the output OFF light level and return to Run mode. 	<p>Accepted</p> <ol style="list-style-type: none"> 1. The amber LED indicator is off and the green indicator LED flashes three times. 2. The green and amber LED indicators flash six times rapidly in unison (acceptance flash). 3. The sensor returns to Run mode with valid thresholds.
Dynamic TEACH	<ol style="list-style-type: none"> 1. Press and hold the Push Button for greater than 2 seconds to start the Dynamic TEACH process. 2. Run the target application to configure the ON and OFF conditions. 3. Click the Push Button once to stop the Dynamic TEACH process and return to Run mode. 	<p>Invalid Teach Condition</p> <ol style="list-style-type: none"> 1. The green and amber indicator LEDs flash two times in unison. 2. The green and amber LED Indicators flash six times rapidly in unison (acceptance flash). 3. The sensor returns to Run Mode with coerced thresholds.
Window SET	<ol style="list-style-type: none"> 1. Present the target condition. 2. Press and hold the button for greater than 2 seconds to configure the target condition and return to Run mode. 	
Light SET		
Dark SET		

IO-Link

Action		Result
Two-Point Static TEACH	<ol style="list-style-type: none"> 1. Present the output ON target condition. 2. Send SP1 Two Value Teach TP1 command using IO-Link to enter TEACH mode and learn the output ON light level. 3. Present the output OFF target condition. 4. Send the SP1 Two Value Teach TP2 command using IO-Link to configure the output OFF light level and return to Run mode. 	<p>Accepted</p> <ol style="list-style-type: none"> 1. The amber LED indicator is off and the green indicator LED flashes three times. 2. The green and amber LED indicators flash six times rapidly in unison (acceptance flash). 3. The sensor returns to Run mode with valid thresholds.
Dynamic TEACH	<ol style="list-style-type: none"> 1. Send SP1 Dynamic Teach Start command using IO-Link to start the Dynamic TEACH process. 2. Run the target application to configure the ON and OFF conditions. 3. Send SP1 Dynamic Teach Stop command using IO-Link to stop the Dynamic TEACH process and return to Run mode. 	<p>Invalid Teach Condition</p> <ol style="list-style-type: none"> 1. The green and amber indicator LEDs flash two times in unison. 2. The green and amber LED Indicators flash six times rapidly in unison (acceptance flash). 3. The sensor returns to Run Mode with coerced thresholds.
Window SET	<ol style="list-style-type: none"> 1. Present the target condition. 2. Send the SP1 Single Value Teach command using IO-Link to configure the target condition and return to Run mode. 	
Light SET		
Dark SET		

Remote Input

Action		Result
Two-Point Static TEACH	<ol style="list-style-type: none"> 1. Present the output ON target condition. 2. Pulse the remote line once to enter TEACH mode and configure the output ON light level. 3. Present the output OFF target condition. 4. Pulse the remote line again to configure the output OFF light level and return to Run mode. 	<p>Accepted</p> <ol style="list-style-type: none"> 1. The amber LED indicator is off and the green indicator LED flashes three times. 2. The green and amber LED indicators flash six times rapidly in unison (acceptance flash). 3. The sensor returns to Run mode with valid thresholds.
Dynamic TEACH	<ol style="list-style-type: none"> 1. Pulse the remote line once to start the Dynamic TEACH process. 2. Run the target application to configure the ON and OFF conditions. 3. Pulse the remote line again to stop the Dynamic TEACH process and return to Run mode. 	<p>Invalid Teach Condition</p> <ol style="list-style-type: none"> 1. The green and amber indicator LEDs flash two times in unison. 2. The green and amber LED Indicators flash six times rapidly in unison (acceptance flash). 3. The sensor returns to Run Mode with coerced thresholds.
Window SET	<ol style="list-style-type: none"> 1. Present the target condition. 2. Pulse the remote line once to configure the target condition and return to Run mode. 	
Light SET		
Dark SET		

6 TEACH/SET

Two-Point Static TEACH

- Two-Point Static TEACH locates a single switching threshold (switchpoint) centered between the two taught conditions, with the Output ON condition on one side, and the Output OFF condition on the other.
- During Two-Point Static TEACH, the first condition taught is the ON condition. Output ON and OFF conditions may be reversed by switching the TEACH order or by changing the Light/Dark Operate setting.
- Two-Point Static TEACH is recommended for applications where two conditions can be presented individually.

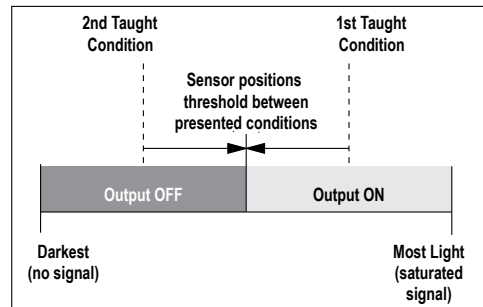

Dynamic TEACH

- Dynamic TEACH locates a single switching threshold (switchpoint) centered between the two taught conditions, with the Output ON condition on one side, and the Output OFF condition on the other.
- During Dynamic TEACH, the Output ON state (Light or Dark Operate setting) remains as it was last configured. Output ON and OFF conditions may be reversed by switching the TEACH order or by changing the Light/Dark Operate setting.
- Dynamic TEACH is recommended for applications where a machine or process may not be stopped for configuration.

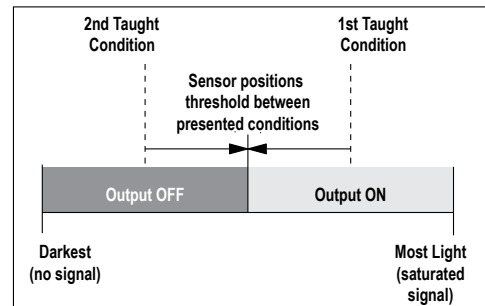

Window SET

- In Window SET, the single ON condition window extends above and below the presented condition by the user selectable offset percentage (30% default). Output ON and OFF conditions may be reversed by changing the Light/Dark Operate setting.
- Lighter or darker conditions outside of the window cause the output to change state.
- Window SET is recommended for applications where the target to be sensed may not always appear in the same place, or when other unwanted signals may appear.

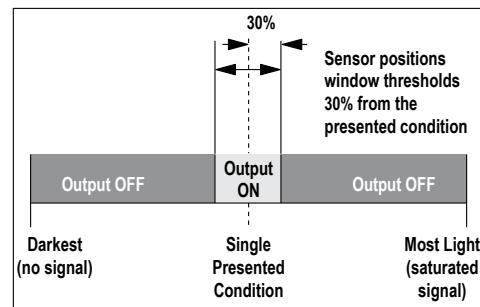

Light SET

- Light SET sets a threshold below the presented condition by the user selectable offset percentage (30% default).
- Any condition darker than the threshold causes the output to change state.
- In Light Operate mode, the presented condition is the Output ON condition. In Dark Operate mode, the presented condition is the Output OFF condition. Reverse the Output ON and OFF conditions by changing the Light / Dark Operate setting.
- Light SET is recommended for applications where only one condition is known, for example a stable light background with varying darker targets, or in retroreflective applications.

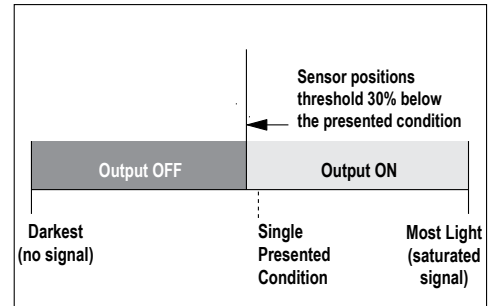

Dark SET

- Dark SET sets a threshold above the presented condition by the user selectable offset percentage (30% default).
- Any condition lighter than the threshold causes the output to change state.
- In Light Operate mode, the presented condition is the Output OFF condition. In Dark Operate mode, the presented condition is the Output ON condition. Reverse the Output ON and OFF conditions by changing the Light / Dark Operate setting.
- Dark SET is recommended for applications where only one condition is known, for example a stable dark background with varying lighter targets, or when maximum excess gain is required.

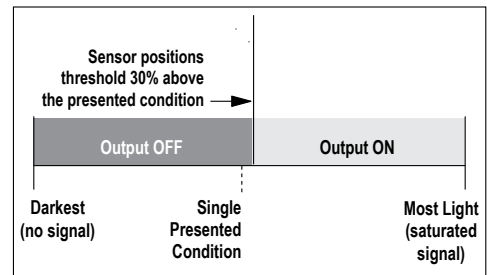

7 Specifications

Supply Voltage and Current

10 V dc to 30 V dc (10% maximum ripple within specified limits) at 30 mA

Supply Protection Circuitry

Protected against reverse polarity and transient overvoltages

Output Protection Circuitry

Protected against false pulse on power-up and continuous overload or short-circuit of output

Output Configuration

Channel 1: IO-Link, Push/pull output, configurable PNP or NPN output
Channel 2: Multi-function remote input/output, configurable PNP or NPN

Output Response Time

Momentary delay on power-up, < 0.5 s, output does not conduct during this time
 350 microseconds ON & OFF for high speed response time
 1 millisecond ON & OFF for standard response time
 2 millisecond ON & 1 millisecond OFF for robust response time

Repeatability

140 microseconds for high speed
 175 microseconds for standard and robust

IO-Link Interface

Supports Smart Sensor Profile: Yes
Baud Rate: 38400 bps
Process Data Widths: 32 bits In, 8 bits Out
IODD Files: Provides all programming options of push button and remote input wire, plus additional functionality. See the IO-Link Data Reference Guide for more details.

Required Overcurrent Protection



WARNING: Electrical connections must be made by qualified personnel in accordance with local and national electrical codes and regulations.

Overcurrent protection is required to be provided by end product application per the supplied table.
 Overcurrent protection may be provided with external fusing or via Current Limiting, Class 2 Power Supply.
 Supply wiring leads < 24 AWG shall not be spliced.
 For additional product support, go to www.bannerengineering.com.

Supply Wiring (AWG)	Required Overcurrent Protection (Amps)
20	5.0
22	3.0
24	2.0
26	1.0
28	0.8
30	0.5

Emitter LED

DV, CV, FP, and LP: Visible red, 625 nm
 D models: Infrared, 940 nm

Indicators

Two LEDs (1 green, 1 amber)
Green On: Indicates power applied and sensor ready
Green Flashing: Indicates sensor operating in marginal state, in need of reconfiguration
Amber On: Indicates output conducting

Factory Default Settings

Setting	Factory Default
TEACH/SET	D, DV, CV, and FP Models: Two-point Static TEACH LP Models: Light SET
Output Logic	D, DV, CV, and FP Models: Light Operate LP Models: Dark Operate
Output Response Time	Standard
Offset Percentage	30%
Push Button	Unlocked
Auto Compensation	Enabled
OFF Delay	Disabled
Pin 4 Output	IO-Link Enabled Detection Output (Push-pull)
Pin 2 Output	Detection Output: High-speed output when using IO-Link on Pin 4

Construction

Housing: ABS
 Window: PMMA

Mounting Torque

Nose Mount: 18 mm mounting nut, 20 lbf-in (2.3 N-m)
Side Mount: Two M3 screws, 5 lbf-in (0.6 N-m)

Connections

PVC-jacketed 4-conductor 2 m (6.5 ft) or 9 m (30 ft) unterminated cable, or 4-pin M12/Euro-style or 4-pin M8/Pico-style quick-disconnect, either integral or 150 mm (6 in) cable, are available.
 Models with a quick disconnect require a mating cordset

Operating Conditions

-40 °C to +70 °C (-40 °F to +158 °F)
 95% at +50 °C maximum relative humidity (non-condensing)

Environmental Rating

IEC IP67

Application Notes

If the push button does not appear to be responsive, perform the push button enable procedure

Certifications



7.1 Dimensions

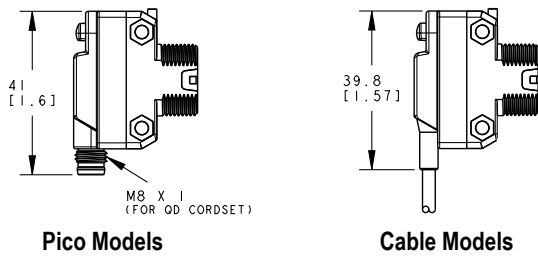
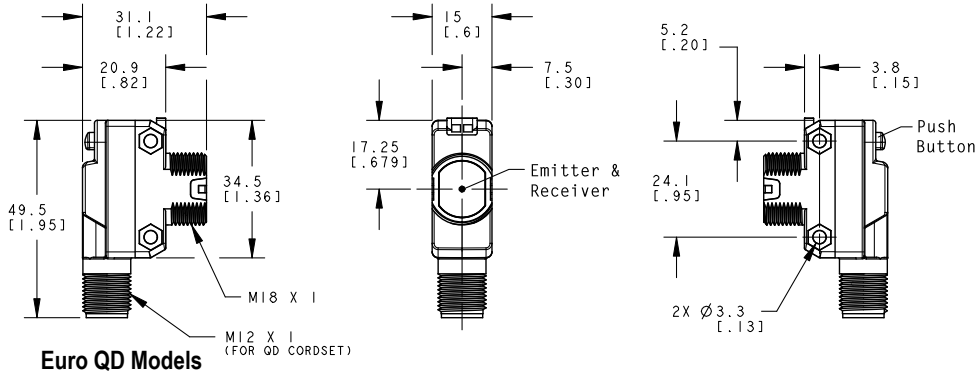

Model Suffix FP

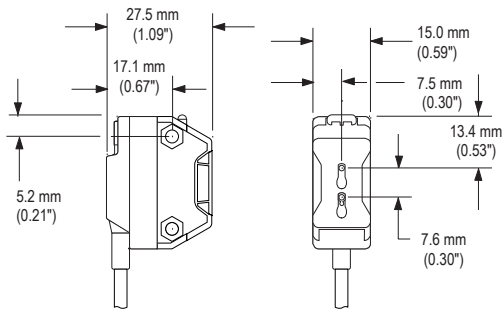

7.2 Performance Curves

Performance using Dark SET, performed in no-light condition.

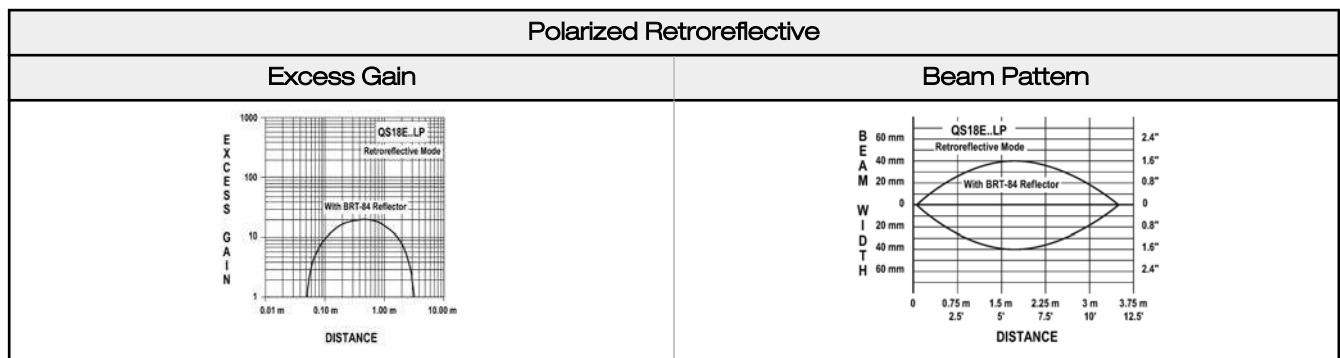

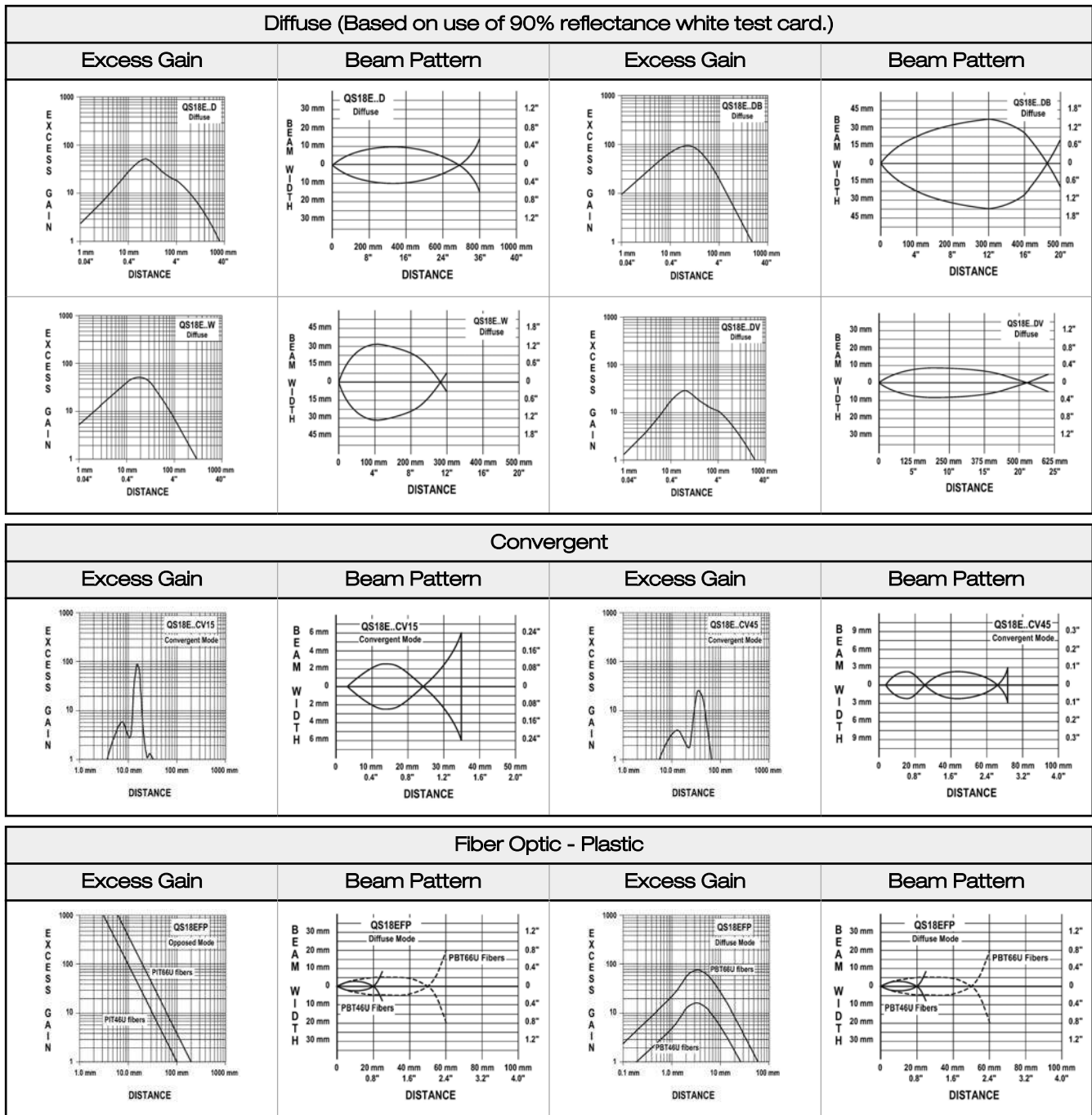

8 Accessories

8.1 Cordsets

4-Pin Threaded M12/Euro-Style Cordsets				
Model	Length	Style	Dimensions	Pinout (Female)
MQDC-406	1.83 m (6 ft)	Straight		<p>1 = Brown 2 = White 3 = Blue 4 = Black</p>
MQDC-415	4.57 m (15 ft)			
MQDC-430	9.14 m (30 ft)			
MQDC-450	15.2 m (50 ft)			
MQDC-406RA	1.83 m (6 ft)	Right-Angle		
MQDC-415RA	4.57 m (15 ft)			
MQDC-430RA	9.14 m (30 ft)			
MQDC-450RA	15.2 m (50 ft)			

4-Pin Threaded M8/Pico-Style Cordsets				
Model	Length	Style	Dimensions	Pinout (Female)
PKG4M-2	2 m (6.56 ft)	Straight		<p>1 = Brown 2 = White 3 = Blue 4 = Black</p>
PKG4M-5	5 m (16.4 ft)			
PKG4M-9	9 m (29.5 ft)			
PKW4M-2	2 m (6.56 ft)	Right Angle		
PKW4M-5	5 m (16.4 ft)			
PKW4M-9	9 m (29.5 ft)			

8.2 Retroreflectors

BRT-51X51BM

- Square, acrylic target
- Reflectivity Factor: 1.5
- Temperature: -20 °C to +50 °C (-4 °F to +122 °F)
- Micro-prism geometry
- Optional brackets are available
- Approximate size: 51 mm x 51 mm

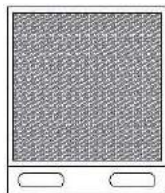

BRT-60X40C

- Rectangular, acrylic target
- Reflectivity Factor: 1.4
- Temperature: -20 °C to +60 °C (-4 °F to +140 °F)
- Optional brackets are available
- Approximate size: 40 mm x 60 mm

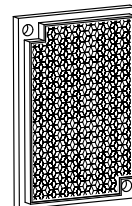

BRT-92X92C

- Square, acrylic target
- Reflectivity Factor: 3.0
- Temperature: -20 °C to +60 °C (-4 °F to +140 °F)
- Optional brackets are available
- Approximate size: 92 mm x 92 mm



BRT-40X19A

- Rectangular, acrylic target
- Reflectivity Factor: 1.3
- Temperature: -20 °C to +60 °C (-4 °F to +140 °F)
- Approximate size: 19 mm x 60 mm overall; 19 mm x 40 mm reflector

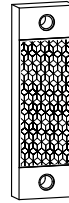

2 in retroreflective tape, 2.5 m (100 in)

Model	Reflectivity Factor	Maximum Temperature	Size
BRT-THG-2-100	0.7	+60 °C (+140 °F)	50 mm (2 in) wide, 2.5 m (100 in) long

8.3 Brackets

SMB18A

- Right-angle mounting bracket with a curved slot for versatile orientation
- 12-ga. stainless steel
- 18 mm sensor mounting hole
- Clearance for M4 (#8) hardware

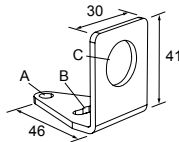

Hole center spacing: A to B = 24.2

Hole size: A = \varnothing 4.6, B = 17.0 x 4.6, C = \varnothing 18.5

SMBQS18Y

- Die-cast bracket for 18 mm holes
- Includes metal hex nut and lock washer
- Allows $\pm 8^\circ$ for cabled sensors

Hole size: A = \varnothing 15.3

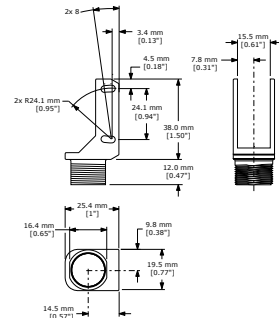

SMBQ4X..

- Swivel bracket with tilt and pan movement for precision adjustment
- Easy sensor mounting to extruded rail T-slots
- Metric and inch size bolts available
- Side mounting of some sensors with the 3 mm screws included with the sensor

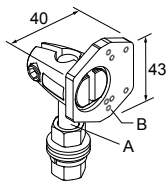

B = 7 x M3 x 0.5

Model	Bolt Thread (A)
SMBQ4XF A	3/8 - 16 x 2 1/4 in
SMBQ4XFAM10	M10 - 1.5 x 50
SMBQ4XFAM12	n/a; no bolt included. Mounts directly to 12 mm (1/2 in) rods

SMB18AFA..

- Protective, swivel bracket with tilt and pan movement for precision adjustment
- Easy sensor mounting to extruded rail T-slots
- Metric and inch size bolts available
- Mounting hole for 18 mm sensors

Hole size: B = \varnothing 18.1

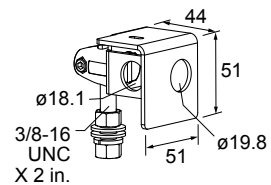

Model	Bolt Thread (A)
SMB18AFA	3/8 - 16 x 2 in
SMB18AFAM10	M10 - 1.5 x 50

SMB312S

- Stainless steel 2-axis, side-mount bracket

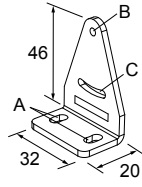

A = 4.3 × 7.5, B = diam. 3, C = 3 × 15.3

9 Contact Us

Corporate Headquarters

Address:
Banner Engineering Corporate
9714 Tenth Avenue North
Minneapolis, Minnesota 55441, USA

Phone: +1 763 544 3164
Website: www.bannerengineering.com

Europe

Address:
Banner Engineering EMEA
Park Lane, Culliganlaan 2F, bus 3
1831 Diegem, Belgium

Phone: +32 (0)2 456 0780
Website: www.bannerengineering.com
Email: mail@bannerengineering.com

Turkey

Address:
Banner Engineering Elk. San. Ve Tic. Ltd. Şti.
Şerifali Mah. Münevver Sok. Ekomed Plaza No:10 Kat:4
Ümraniye / İstanbul, Türkiye

Phone: +90 216 688 8282
Website: www.bannerengineering.com
Email: turkey@bannerengineering.com.tr

India

Address:
Banner Engineering India Pune Head Quarters
Office No. 1001, 10th Floor Sai Capital, Opp. ICC Senapati Bapat Road
Pune 411016, India

Phone: +91 (0) 206 640 5624
Website: www.bannerengineering.com
Email: salesindia@bannerengineering.com

Mexico

Address:
Banner Engineering de Mexico Monterrey Head Office
Edificio VAO Av. David Alfaro Siqueiros No.103 Col. Valle Oriente C.P.66269
San Pedro Garza Garcia, Nuevo Leon, Mexico

Phone: +52 81 8363 2714 or 01 800 BANNERE (toll free)
Website: www.bannerengineering.com
Email: mexico@bannerengineering.com

Brazil

Address:
Banner do Brasil
Rua Barão de Teffé nº 1000, sala 54
Campos Eliseos, Jundiaí - SP, CEP.: 13208-761, Brasil

Phone: +55 11 2709 9880
Website: www.bannerengineering.com
Email: brasil@bannerengineering.com

China

Address:
Banner Engineering Shanghai Rep Office
Xinlian Scientific Research Building Level 12, Building 2
1535 Hongmei Road, Shanghai 200233, China

Phone: +86 212 422 6888
Website: www.bannerengineering.com
Email: sensors@bannerengineering.com.cn

Japan

Address:
Banner Engineering Japan
Cent-Urban Building 305 3-23-15 Nishi-Nakajima Yodogawa-Ku
Osaka 532-0011, Japan

Phone: +81 (0)6 6309 0411
Website: www.bannerengineering.com
Email: mail@bannerengineering.co.jp

Taiwan

Address:

Banner Engineering Taiwan
8F-2, No. 308 Section 1, Neihu Road
Taipei 114, Taiwan

Phone: +886 (0)2 8751 9966

Website: www.bannerengineering.com

Email: info@bannerengineering.com.tw

10 Banner Engineering Corp. Limited Warranty

Banner Engineering Corp. warrants its products to be free from defects in material and workmanship for one year following the date of shipment. Banner Engineering Corp. will repair or replace, free of charge, any product of its manufacture which, at the time it is returned to the factory, is found to have been defective during the warranty period. This warranty does not cover damage or liability for misuse, abuse, or the improper application or installation of the Banner product.

THIS LIMITED WARRANTY IS EXCLUSIVE AND IN LIEU OF ALL OTHER WARRANTIES WHETHER EXPRESS OR IMPLIED (INCLUDING, WITHOUT LIMITATION, ANY WARRANTY OF MERCHANTABILITY OR FITNESS FOR A PARTICULAR PURPOSE), AND WHETHER ARISING UNDER COURSE OF PERFORMANCE, COURSE OF DEALING OR TRADE USAGE.

This Warranty is exclusive and limited to repair or, at the discretion of Banner Engineering Corp., replacement. **IN NO EVENT SHALL BANNER ENGINEERING CORP. BE LIABLE TO BUYER OR ANY OTHER PERSON OR ENTITY FOR ANY EXTRA COSTS, EXPENSES, LOSSES, LOSS OF PROFITS, OR ANY INCIDENTAL, CONSEQUENTIAL OR SPECIAL DAMAGES RESULTING FROM ANY PRODUCT DEFECT OR FROM THE USE OR INABILITY TO USE THE PRODUCT, WHETHER ARISING IN CONTRACT OR WARRANTY, STATUTE, TORT, STRICT LIABILITY, NEGLIGENCE, OR OTHERWISE.**

Banner Engineering Corp. reserves the right to change, modify or improve the design of the product without assuming any obligations or liabilities relating to any product previously manufactured by Banner Engineering Corp. Any misuse, abuse, or improper application or installation of this product or use of the product for personal protection applications when the product is identified as not intended for such purposes will void the product warranty. Any modifications to this product without prior express approval by Banner Engineering Corp will void the product warranties. All specifications published in this document are subject to change; Banner reserves the right to modify product specifications or update documentation at any time. Specifications and product information in English supersede that which is provided in any other language. For the most recent version of any documentation, refer to: www.bannerengineering.com.

For patent information, see www.bannerengineering.com/patents.