

Instruction Manual

Expert™ Coaxial Polarized Retroreflective Sensor for Clear Object Detection

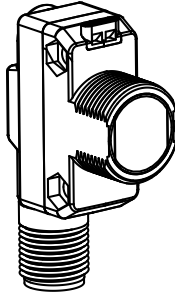

- Reliably detects clear, translucent, or opaque objects — including PET, glass containers, and transparent films
- Coaxial optics enable reliable detection of targets to the face of the sensor with no dead zone
- "Clear Tracking" automatic compensation algorithm provides long and reliable operation by compensating for dust build up and ambient temperature changes
- Fast response speed with low jitter for high speed bottling and packaging applications
- Bright, visible red light spot makes alignment easy
- 3 user-selectable thresholds optimize performance to the type of object being detected
- Easy configuration of sensor by remote teach input or tactile push button
- Convenient mounting options available for 18 mm barrel or side mount
- Bright indicator LEDs show operating status from 360°
- IP67 rated ABS housing
- Dedicated PNP or NPN output with matching remote input wire



WARNING: Not To Be Used for Personnel Protection

Never use this device as a sensing device for personnel protection. Doing so could lead to serious injury or death. This device does not include the self-checking redundant circuitry necessary to allow its use in personnel safety applications. A sensor failure or malfunction can cause either an energized or de-energized sensor output condition.

Models

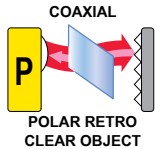
Models	Mode	Range	Output	Connector ¹
QS18EN6XLPC		0 to 1.3 m (0 to 4.2 ft) on BRT-40X19A	NPN	2 m cable (6.5 ft)
QS18EP6XLPC		0 to 2.0 m (0 to 6.5 ft) on BRT-51X51BM 0 to 3.0 m (0 to 9.8 ft) on BRT-92X92C	PNP	

¹ The standard 2 m (6.5 ft) cable models are listed.

- To order the 9 m (30 ft) cable models, add the suffix "W/30" to the cabled model number (for example QS18EN6XLPC W/30)
- To order the 4 pin Euro M12 integral connector, add the suffix "Q8" (for example QS18EN6LPCQ8)
- To order the 4 pin Euro M12 150 mm (6 inch) cable, add the suffix "Q5" (for example QS18EN6LPCQ5)
- To order a 4 pin Pico M8 integral connector, add the suffix "Q7" (for example QS18EN6LPCQ7)
- To order a 4 pin Pico M8 150 mm (6 inch) cable, add the suffix "Q" (for example QS18EN6XLPCQ)



Overview

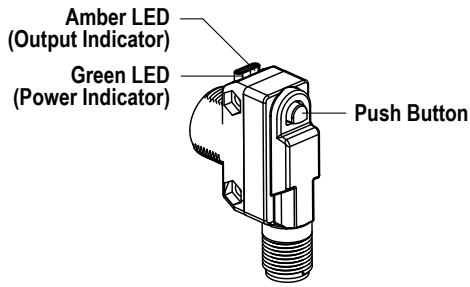

The Banner QS18 sensor is a high performance clear object detection sensor. The polarized coaxial optical design ensures reliable detection of transparent, translucent, and opaque targets at any distance between the sensor and the reflector. Low contrast sensing applications include PET bottles, glass containers, and shrink wrap. The sensor can also be used to detect optical surfaces such as: LCD panels with built in polarizing films, solar panels, and semiconductor wafers.

Indicators (Two LEDs: One Green, One Amber)		
Sensor Condition (Run Mode)	Green LED	Amber LED
Output OFF	ON	OFF
Output ON	ON	ON
Notification — Sensor needs to be reconfigured for reliable detection	Flashing at 5 Hz	ON/OFF
Notification — Push button has been locked out	Flashes 4 times and returns to solid on	ON/OFF

Installing and Mounting the Sensor for Low Contrast Applications

Reliable transparent object detection depends on the sensor always detecting the object as "dark state" and the reflector as the "light state". Using a recommended reflector, and proper orientation of the sensor to the reflector, is key to good clear object detection. Optimize the reliable detection of transparent and clear objects by applying the following steps when mounting the sensor and selecting a retroreflective target.

1. If a bracket is needed, mount the sensor onto the bracket.
2. Mount the sensor (or the sensor and the bracket) to the equipment at the desired location. Do not tighten at this time.
3. Align the sensor's light spot to the middle of the retroreflector.
4. Mount the retroreflector perpendicular to the sensor optical axis ($\pm 5^\circ$).
5. Tighten the screws to secure the sensor (or the sensor and the bracket) to the aligned position.

Mounting Considerations for Opaque Objects with Mirror Like Surfaces

To minimize the potential for reflections from mirror like objects affecting the sensor, it is best to side mount the sensor.

Wiring Diagrams

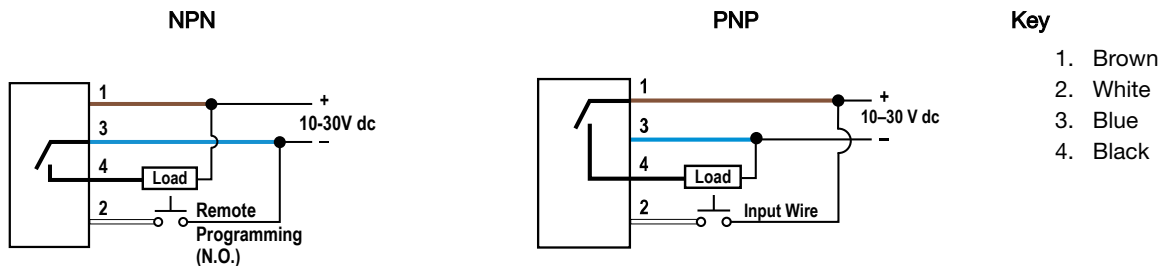

Sensor Configuration

Sensor configuration can be implemented with the push button or the remote program wire. Configuration options include two sensing modes: Light Set and Dark Set. Configuration options include the features shown in Push Button Input Flowchart and Remote Input Flowchart.

Push Button Configuration

Use the push button to configure the sensor. Click the push button according to Push Button Input Flowchart. After a configuration has been selected the sensor flashes both the green and amber LED to show which configuration was selected followed by a rapid flashing of both the green and amber LED in unison to show acknowledgement and acceptance of the configuration.

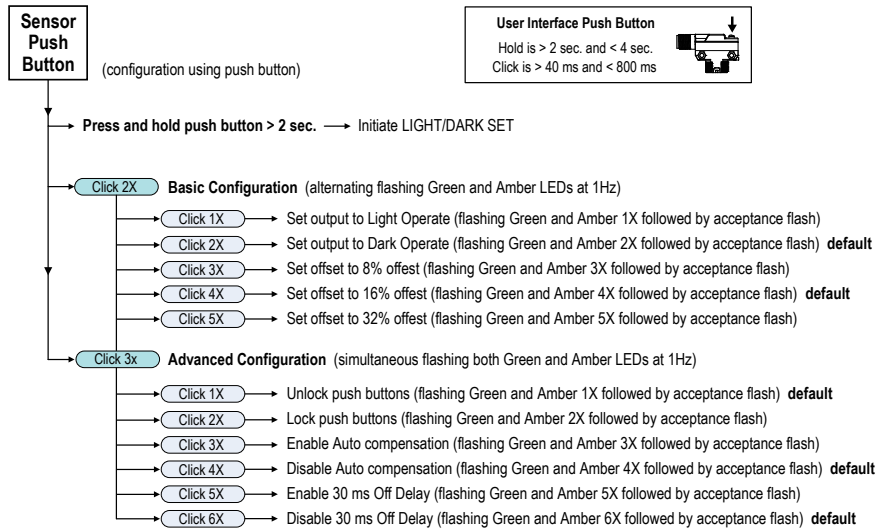

Figure 1. Push Button Input Flowchart

Remote Input Configuration

Enabling the remote input wire is done using IO-Link. Use the remote input function to configure the sensor remotely. Connect the white wire of the sensor as shown in the wiring diagram. Pulse the remote line according to the Remote Input Flowchart. After a configuration has been selected, both the green and amber LEDs will flash to show which configuration was selected, followed by a rapid flashing of both the green and amber LED in unison to show acknowledgement and acceptance of the configuration.

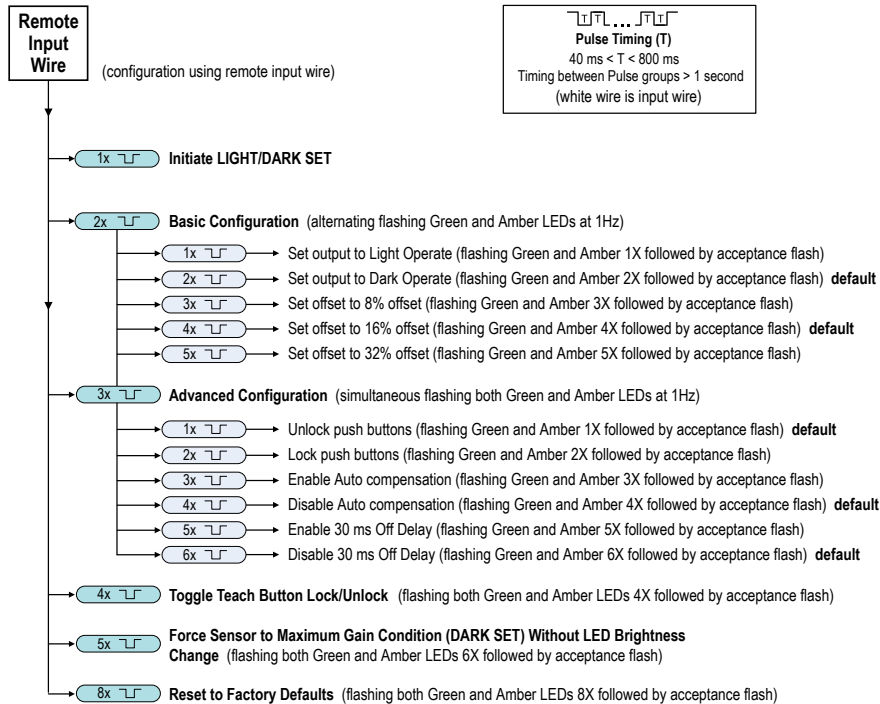

Figure 2. Remote Input Flowchart

Light Set

Use Light SET for low contrast applications. Use either the push button or remote input wire procedure to configure the sensor.

Example Applications For Offset Percentages	
8%	Recommended for very low contrast applications with stable environmental conditions.
16%	Recommended for most clear object detection applications in typical machine industrial environments.
32%	Recommended for high contrast detections such as brown or green bottles, or opaque objects. This setting tolerates environmental challenges such as vibrations and dust build-up.

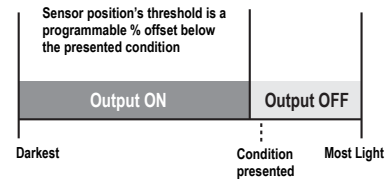

Figure 3. LIGHT SET sensing mode in dark operate

1. Prepare the sensor.

Method	Action	Result
Push Button	Clear the light path to the reflector.	
Remote Line	Clear the light path to the reflector.	

2. Access Light Set mode and set the sensing condition.

Method	Action	Result
Push Button	Press and hold the push button 2 to 4 seconds.	<p>LIGHT SET Configuration Accepted Green LED Indicator: Flashes 3 times. Green and Amber LED Indicators: Acceptance Flash - both LEDs flash 5 times rapidly in unison.</p> <p>The sensor returns to Run mode with the new settings.</p> <p>LIGHT SET Configuration Not Accepted If there is not enough return signal, the sensor will perform in DARK SET indicated by the green and amber LED indicators flashing in unison 2 times followed by the green and amber LED indicators flashing rapidly in unison 5 times.</p>
Remote Line	Single-pulse the remote line.	

Dark Set

Dark SET (maximum operating range) is the factory default setting and provides maximum sensing range, ease of alignment, and reliable detection of opaque objects. Dark Set provides a fixed threshold whenever the sensor is taught an obstructed view.



Note: The sensor's light spot is made brighter for 60 seconds to assist in aligning the sensor to the reflector. This is particularly useful for long range applications.

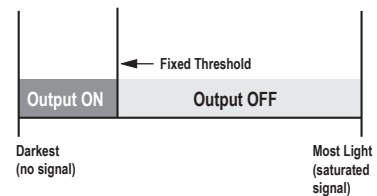



Figure 4. DARK SET sensing mode in dark operate

1. Prepare the sensor.

Method	Action	Result
Push Button	Block the light path to the reflector.	
Remote Line	Block the light path to the reflector.	

2. Access Dark Set mode and set the sensing condition.

Method	Action	Result
Push Button	Press and hold the push button 2 to 4 seconds. 	DARK SET Configuration Accepted Green and Amber LED Indicators: Flash 2 times. Green and Amber LED Indicators: Acceptance flash - both LEDs flash 5 times rapidly in unison. The sensor returns to Run mode with the new settings.
Remote Line	Single-pulse the remote line. 	DARK SET Configuration Not Accepted If there is too much return signal, the sensor will perform in LIGHT SET indicated by the green LED indicator flashing 3 times followed by the green and amber LED indicators flashing rapidly in unison 5 times.

Specifications

Supply Voltage

10 V to 30 V dc (10% maximum ripple)

Supply Current (Exclusive of Load Current)

< 25 mA at 15 V
< 40 mA at 24 V

Repeatability

100 µs

Supply Protection Circuitry

Protected against reverse polarity and transient voltages

Output Protection Circuitry

Protected against false pulse on power-up and continuous overload or short-circuit of output

Output Configuration

Current sourcing (PNP) or current sinking (NPN), depending on model; Light- or dark-operate selectable; Selectable 30 ms output OFF-delay
Rating: 100 mA max

Off-state leakage current: < 50 µA at 30 V

ON-state saturation voltage: < 1.5 V at 10 mA; < 3 V 100 mA

Output Response Time

Note: Momentary delay on power-up; output does not conduct during this time

400 µs ON/OFF

Required Overcurrent Protection



WARNING: Electrical connections must be made by qualified personnel in accordance with local and national electrical codes and regulations.

Overcurrent protection is required to be provided by end product application per the supplied table.
Overcurrent protection may be provided with external fusing or via Current Limiting, Class 2 Power Supply.
Supply wiring leads < 24 AWG shall not be spliced.
For additional product support, go to www.bannerengineering.com.

Supply Wiring (AWG)	Required Overcurrent Protection (Amps)
20	5.0
22	3.0
24	2.0
26	1.0
28	0.8
30	0.5

Emitter LED

Visible red, 625 nm

Indicators

Two LEDs (1 green, 1 amber)

Green solid: Indicates power applied and sensor ready

Green flashing: Indicates sensor operating in marginal state, in need of reconfiguration

Amber solid: Indicates output conducting

Factory Default Settings

Setting	Factory Default
Sensing Mode	Dark Set
Output Logic	Dark Operate
Offset Percent	16%
Push Button	Unlocked
Auto Compensation	Disabled
OFF Delay	Disabled

Mounting Torque

Nose mount: 18 mm mounting nut, 20 lbf-in (2.3 N-m)

Side mount: Two M3 screws, 5 lbf-in (0.6 N-m)

Construction

ABS housing, PMMA window

Connections

PVC-jacketed 4-conductor 2 m (6.5 ft) or 9 m (30 ft) unterminated cable, or 4-pin Euro-style or 4-pin Pico-style quick-disconnect (QD), either integral or 150 mm (6 in) pigtail, are available. QD cordsets are ordered separately.

Operating Conditions

Temperature: -40 °C to +70 °C (-40 °F to +158 °F)

Relative Humidity: 90% at +50 °C (non-condensing)

Environmental

IEC IP67

Application Notes

If the push button does not appear to be responsive, perform the push button enable procedure

Certifications



Dimensions

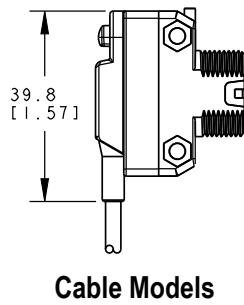
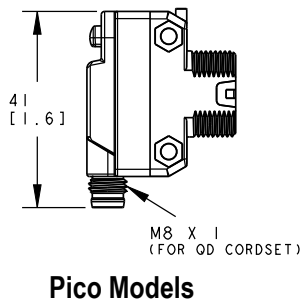
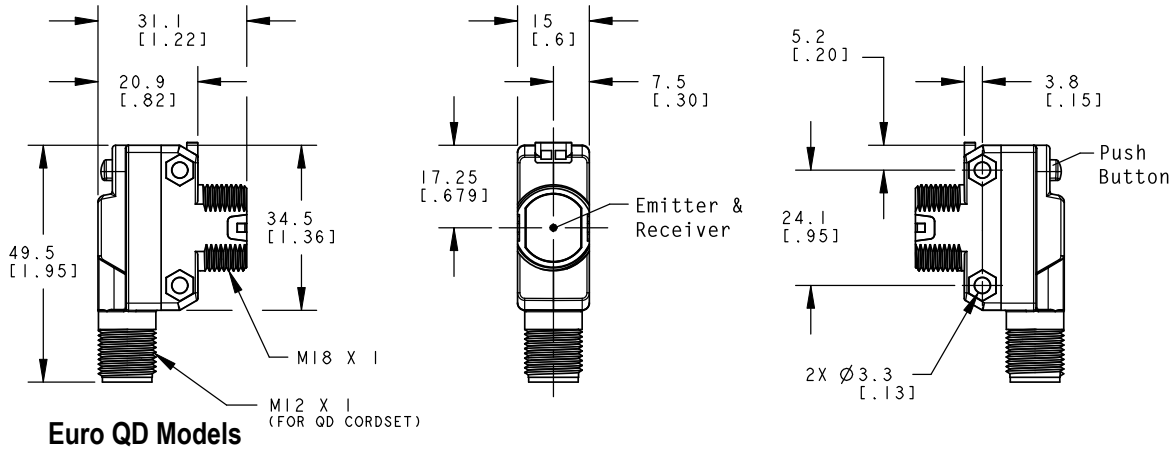

Performance Curves

Spot Size vs. Distance

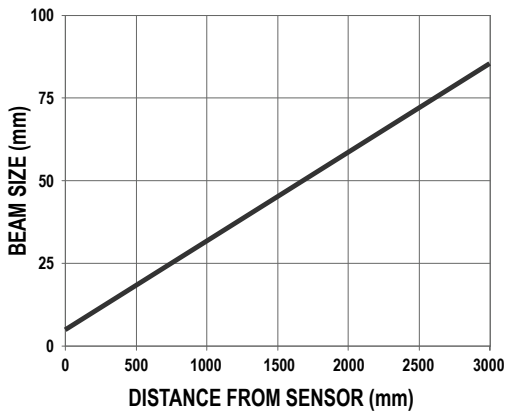

Excess Gain

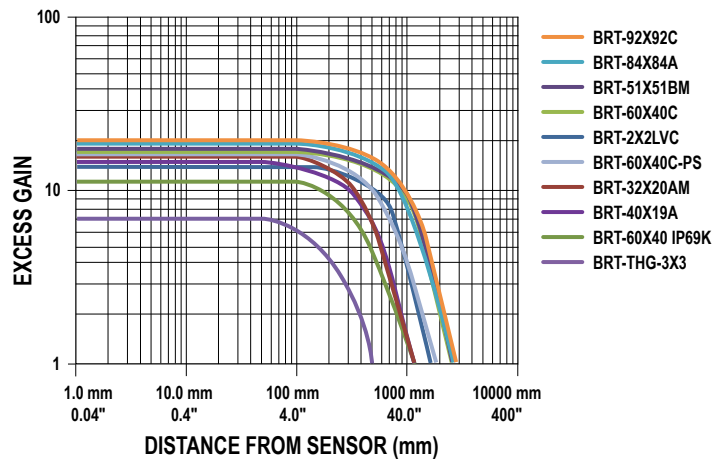

Accessories

Cordsets

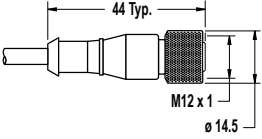
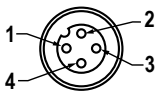
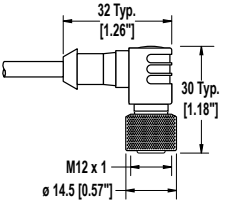
4-Pin Threaded M12/Euro-Style Cordsets				
Model	Length	Style	Dimensions	Pinout (Female)
MQDC-406	1.83 m (6 ft)	Straight		 <p>1 = Brown 2 = White 3 = Blue 4 = Black</p>
MQDC-415	4.57 m (15 ft)			
MQDC-430	9.14 m (30 ft)			
MQDC-450	15.2 m (50 ft)			
MQDC-406RA	1.83 m (6 ft)	Right-Angle		
MQDC-415RA	4.57 m (15 ft)			
MQDC-430RA	9.14 m (30 ft)			
MQDC-450RA	15.2 m (50 ft)			

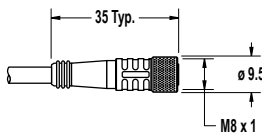
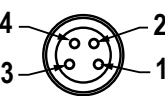
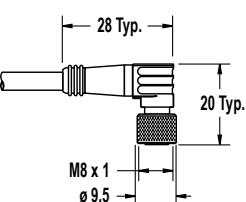
4-Pin Threaded M8/Pico-Style Cordsets				
Model	Length	Style	Dimensions	Pinout (Female)
PKG4M-2	2 m (6.56 ft)	Straight		 <p>1 = Brown 2 = White 3 = Blue 4 = Black</p>
PKG4M-5	5 m (16.4 ft)			
PKG4M-9	9 m (29.5 ft)			
PKW4M-2	2 m (6.56 ft)	Right Angle		
PKW4M-5	5 m (16.4 ft)			
PKW4M-9	9 m (29.5 ft)			

Retroreflectors

BRT-51X51BM

- Square, acrylic target
- Reflectivity Factor: 1.5
- Temperature: -20 °C to +50 °C (-4 °F to +122 °F)
- Micro-prism geometry
- Optional brackets are available
- Approximate size: 51 mm x 51 mm

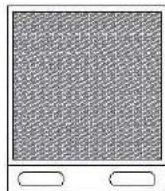

BRT-60X40C

- Rectangular, acrylic target
- Reflectivity Factor: 1.4
- Temperature: -20 °C to +60 °C (-4 °F to +140 °F)
- Optional brackets are available
- Approximate size: 40 mm x 60 mm

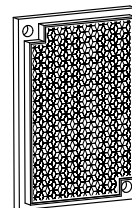

BRT-92X92C

- Square, acrylic target
- Reflectivity Factor: 3.0
- Temperature: -20 °C to +60 °C (-4 °F to +140 °F)
- Optional brackets are available
- Approximate size: 92 mm x 92 mm



BRT-40X19A

- Rectangular, acrylic target
- Reflectivity Factor: 1.3
- Temperature: -20 °C to +60 °C (-4 °F to +140 °F)
- Approximate size: 19 mm x 60 mm overall; 19 mm x 40 mm reflector

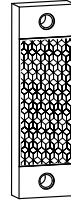

BRT-60X40IP69K

- Rectangular, acrylic target (color is amber)
- Reflectivity Factor: 0.7
- Temperature: -20 °C to +140 °C (-4 °F to +284 °F)
- Chemically resistant
- IP69K washdown rated
- Optional brackets are available
- Approximate size: 40 mm x 60 mm

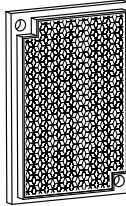

BRT-60X40C-PS

- Rectangular, polystyrene target
- Reflectivity Factor: 1.1
- Temperature: -20 °C to +60 °C (-4 °F to +140 °F)
- Optional brackets are available
- Chemically compatible with hydrogen peroxide
- Yellow back
- Approximate size: 40 mm x 60 mm

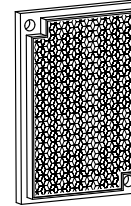

2 in retroreflective tape, 2.5 m (100 in)

Model	Reflectivity Factor	Maximum Temperature	Size
BRT-THG-2-100	0.7	+60 °C (+140 °F)	50 mm (2 in) wide, 2.5 m (100 in) long

Brackets

SMB18A

- Right-angle mounting bracket with a curved slot for versatile orientation
- 12-ga. stainless steel
- 18 mm sensor mounting hole
- Clearance for M4 (#8) hardware

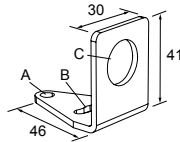

Hole center spacing: A to B = 24.2

Hole size: A = \varnothing 4.6, B = 17.0 x 4.6, C = \varnothing 18.5

SMBQS18Y

- Die-cast bracket for 18 mm holes
- Includes metal hex nut and lock washer
- Allows \pm 8° for cabled sensors

Hole size: A = \varnothing 15.3

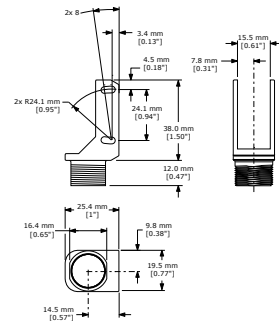

SMBQ4X..

- Swivel bracket with tilt and pan movement for precision adjustment
- Easy sensor mounting to extruded rail T-slots
- Metric and inch size bolts available
- Side mounting of some sensors with the 3 mm screws included with the sensor

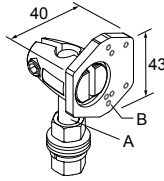

B = 7 × M3 × 0.5

Model	Bolt Thread (A)
SMBQ4XFAM10	M10 - 1.5 × 50
SMBQ4XFAM12	n/a; no bolt included. Mounts directly to 12 mm (½ in) rods

SMB18AFA..

- Protective, swivel bracket with tilt and pan movement for precision adjustment
- Easy sensor mounting to extruded rail T-slots
- Metric and inch size bolts available
- Mounting hole for 18 mm sensors

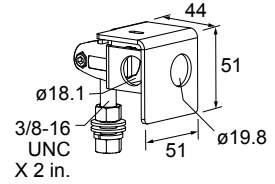

Hole size: B = ø 18.1

Model	Bolt Thread (A)
SMB18AFA	3/8 - 16 × 2 in
SMB18AFAM10	M10 - 1.5 × 50

SMB312S

- Stainless steel 2-axis, side-mount bracket

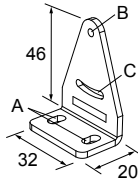

A = 4.3 × 7.5, B = diam. 3, C = 3 × 15.3

Banner Engineering Corp. Limited Warranty

Banner Engineering Corp. warrants its products to be free from defects in material and workmanship for one year following the date of shipment. Banner Engineering Corp. will repair or replace, free of charge, any product of its manufacture which, at the time it is returned to the factory, is found to have been defective during the warranty period. This warranty does not cover damage or liability for misuse, abuse, or the improper application or installation of the Banner product.

THIS LIMITED WARRANTY IS EXCLUSIVE AND IN LIEU OF ALL OTHER WARRANTIES WHETHER EXPRESS OR IMPLIED (INCLUDING, WITHOUT LIMITATION, ANY WARRANTY OF MERCHANTABILITY OR FITNESS FOR A PARTICULAR PURPOSE), AND WHETHER ARISING UNDER COURSE OF PERFORMANCE, COURSE OF DEALING OR TRADE USAGE.

This Warranty is exclusive and limited to repair or, at the discretion of Banner Engineering Corp., replacement. **IN NO EVENT SHALL BANNER ENGINEERING CORP. BE LIABLE TO BUYER OR ANY OTHER PERSON OR ENTITY FOR ANY EXTRA COSTS, EXPENSES, LOSSES, LOSS OF PROFITS, OR ANY INCIDENTAL, CONSEQUENTIAL OR SPECIAL DAMAGES RESULTING FROM ANY PRODUCT DEFECT OR FROM THE USE OR INABILITY TO USE THE PRODUCT, WHETHER ARISING IN CONTRACT OR WARRANTY, STATUTE, TORT, STRICT LIABILITY, NEGLIGENCE, OR OTHERWISE.**

Banner Engineering Corp. reserves the right to change, modify or improve the design of the product without assuming any obligations or liabilities relating to any product previously manufactured by Banner Engineering Corp. Any misuse, abuse, or improper application or installation of this product or use of the product for personal protection applications when the product is identified as not intended for such purposes will void the product warranty. Any modifications to this product without prior express approval by Banner Engineering Corp will void the product warranties. All specifications published in this document are subject to change; Banner reserves the right to modify product specifications or update documentation at any time. Specifications and product information in English supersede that which is provided in any other language. For the most recent version of any documentation, refer to: www.bannerengineering.com.