

Datasheet

For complete technical information about this product, including installation instructions, application requirements and guidelines, EU Declaration of Conformity, technical specifications, and accessories, see www.bannerengineering.com and search 174868.

- Intuitive, icon-based programming with drag-and-drop PC configuration simplifies device setup and management
- Two six-amp safety relay outputs, each with three N.O. sets of contacts
- Ten inputs, including four that can be used as non-safe outputs
- Automatic Terminal Optimization (ATO) can increase the inputs from 10 to up to 14
- Industrial Ethernet two-way communication
 - 256 virtual non-safe status outputs
 - 80 virtual non-safe inputs (reset, on/off, cancel off-delay, mute enable)
- SC-XM3 external drive for fast swap and quick configuration without a PC

Model	Description
SC10-2roe	Configurable safety relay controller - 10 inputs (4 convertible), two 3-channel safety relay outputs, industrial ethernet



Note: Configuration software is required.

The software is available at www.bannerengineering.com/safetycontroller.

SC10-2 Features and Indicators

Connection points are push-in spring clamp connectors.

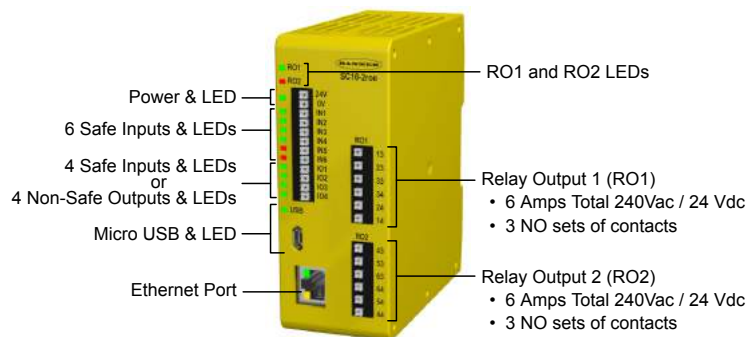

Figure 1. Features and Indicators

SC10-2 Specifications

Power

Voltage: 24 V dc $\pm 20\%$ (SELV)

Current:

- 240 mA maximum, no load (relays on)
- 530 mA maximum, full load (IO1 to IO4 used as auxiliary outputs)

Safety Inputs (and Convertible I/O when used as inputs)

- Input On threshold:** > 15 V dc (guaranteed on), 30 V dc maximum
- Input Off threshold:** < 5 V dc and < 2 mA, -3 V dc minimum
- Input On current:** 5 mA typical at 24 V dc, 50 mA peak contact cleaning current at 24 V dc
- Input lead resistance:** 300 Ω maximum (150 Ω per lead)
- Input requirements for a 4-wire Safety Mat:**
 - Maximum capacity between plates: 0.22 μF ¹
 - Maximum capacity between bottom plate and ground: 0.22 μF ¹
 - Maximum resistance between the 2 input terminals of one plate: 20 Ω

¹ If the safety mats share a convertible I/O, this is the total capacitance of all shared safety mats.

Convertible I/O

- Sourcing current:** 80 mA maximum (overcurrent protected)
- Test Pulses:** ~1 ms every 25 to 75 ms

Automatic Terminal Optimization Feature

Up to three devices connected with user-provided terminal blocks

Network Interface

- Ethernet 10/100 Base-T/TX, RJ45 modular connector
- Selectable auto negotiate or manual rate and duplex
- Auto MDI/MDIX (auto cross)
- Protocols:** EtherNet/IP (with PCCC), Modbus/TCP, and PROFINET
- Data:** 256 virtual Status Outputs; fault diagnostic codes and messages; access to fault log



Response and Recovery Times

Input to Output Response Time (Input Stop to Output Off): see the Configuration Summary in the Software, as it can vary
Input Recovery Time (Stop to Run): 250 ms typical, 400 ms maximum
Virtual Input (Mute Enable and On/Off) Timing: RPI + 200 ms typical
Virtual Input (Manual Reset and Cancel Delay) Timing: see the Instruction Manual for details

Delay Tolerance

±(0.02% + 2 scan times)

Safety Outputs

3 NO sets of contacts for each output channel (RO1 and RO2). Each normally open output is a series connection of contacts from two forced-guided (mechanically linked) relays. RO1 consists of relays K1 and K2. RO2 consists of relays K3 and K4.

See the Instruction Manual for output ratings.

EMC

Meets or exceeds all EMC requirements for immunity per IEC 61326-3-1:2012 and emissions per CISPR 11:2004 for Group 1, Class A equipment

Safety

Category 4, PL e (EN ISO 13849)
 SIL CL 3 (IEC 62061, IEC 61508)

Safety Ratings

PFH [1/h]: 5.01×10^{-10}
Proof Test Interval: 20 years

Product Performance Standards

See Standards and Regulations section in the Instruction Manual for a list of industry applicable U.S. and international standards

Certifications



Operating Conditions

Temperature: 0 °C to +55 °C (+32 °F to +131 °F) (see Temperature Derating graph)
Storage Temperature: -30 °C to +65 °C (-22 °F to +149 °F)
Humidity: 90% at +50 °C maximum relative humidity (non-condensing)
Operating Altitude: 2000 m maximum (6562 ft maximum)

Environmental Rating

NEMA 1 (IEC IP20), for use inside NEMA 3 (IEC IP54) or better enclosure

Mechanical Stress

Shock: 15 g for 11 ms, half sine, 18 shocks total (per IEC 61131-2)
Vibration: 3.5 mm occasional / 1.75 mm continuous at 5 Hz to 9 Hz, 1.0 g occasional and 0.5 g continuous at 9 Hz to 150 Hz: all at 10 sweep cycles per axis (per IEC 61131-2)

Required Overcurrent Protection



WARNING: Electrical connections must be made by qualified personnel in accordance with local and national electrical codes and regulations.

Overcurrent protection is required to be provided by end product application per the supplied table. Overcurrent protection may be provided with external fusing or via Current Limiting, Class 2 Power Supply.

Supply wiring leads < 24 AWG shall not be spliced.

For additional product support, go to www.bannerengineering.com.

Supply Wiring (AWG)	Required Overcurrent Protection (Amps)
20	5.0
22	3.0
24	2.0
26	1.0
28	0.8
30	0.5

Banner Engineering Corp. Limited Warranty

Banner Engineering Corp. warrants its products to be free from defects in material and workmanship for one year following the date of shipment. Banner Engineering Corp. will repair or replace, free of charge, any product of its manufacture which, at the time it is returned to the factory, is found to have been defective during the warranty period. This warranty does not cover damage or liability for misuse, abuse, or the improper application or installation of the Banner product.

THIS LIMITED WARRANTY IS EXCLUSIVE AND IN LIEU OF ALL OTHER WARRANTIES WHETHER EXPRESS OR IMPLIED (INCLUDING, WITHOUT LIMITATION, ANY WARRANTY OF MERCHANTABILITY OR FITNESS FOR A PARTICULAR PURPOSE), AND WHETHER ARISING UNDER COURSE OF PERFORMANCE, COURSE OF DEALING OR TRADE USAGE.

This Warranty is exclusive and limited to repair or, at the discretion of Banner Engineering Corp., replacement. **IN NO EVENT SHALL BANNER ENGINEERING CORP. BE LIABLE TO BUYER OR ANY OTHER PERSON OR ENTITY FOR ANY EXTRA COSTS, EXPENSES, LOSSES, LOSS OF PROFITS, OR ANY INCIDENTAL, CONSEQUENTIAL OR SPECIAL DAMAGES RESULTING FROM ANY PRODUCT DEFECT OR FROM THE USE OR INABILITY TO USE THE PRODUCT, WHETHER ARISING IN CONTRACT OR WARRANTY, STATUTE, TORT, STRICT LIABILITY, NEGLIGENCE, OR OTHERWISE.**

Banner Engineering Corp. reserves the right to change, modify or improve the design of the product without assuming any obligations or liabilities relating to any product previously manufactured by Banner Engineering Corp. Any misuse, abuse, or improper application or installation of this product or use of the product for personal protection applications when the product is identified as not intended for such purposes will void the product warranty. Any modifications to this product without prior express approval by Banner Engineering Corp will void the product warranties. All specifications published in this document are subject to change; Banner reserves the right to modify product specifications or update documentation at any time. Specifications and product information in English supersede that which is provided in any other language. For the most recent version of any documentation, refer to: www.bannerengineering.com.

For patent information, see www.bannerengineering.com/patents.

