

Digital Laser Sensor **Amplifier-separated**

LS-400 SERIES

- Related Information
- General terms and conditions..... F-7
 - Sensor selection guide P.211~
 - SC-GU3 / SC-GU2-C..... P.985~ / P.999
 - Glossary of terms / General precautions..... P.1455~ / P.1458~
 - About laser beam..... P.1499~
 - Korea's S-mark P.1506

- FIBER SENSORS
- LASER SENSORS
- PHOTOELECTRIC SENSORS
- MICRO PHOTOELECTRIC SENSORS
- AREA SENSORS
- LIGHT CURTAINS / SAFETY COMPONENTS
- PRESSURE / FLOW SENSORS
- INDUCTIVE PROXIMITY SENSORS
- PARTICULAR USE SENSORS
- SENSOR OPTIONS
- SIMPLE WIRE-SAVING UNITS
- WIRE-SAVING SYSTEMS
- MEASUREMENT SENSORS
- STATIC ELECTRICITY PREVENTION DEVICES
- LASER MARKERS
- PLC
- HUMAN MACHINE INTERFACES
- ENERGY CONSUMPTION VISUALIZATION COMPONENTS
- FA COMPONENTS
- MACHINE VISION SYSTEMS
- UV CURING SYSTEMS

- Selection Guide
- Amplifier Built-in
- Amplifier-separated
- LS-500
- LS-400

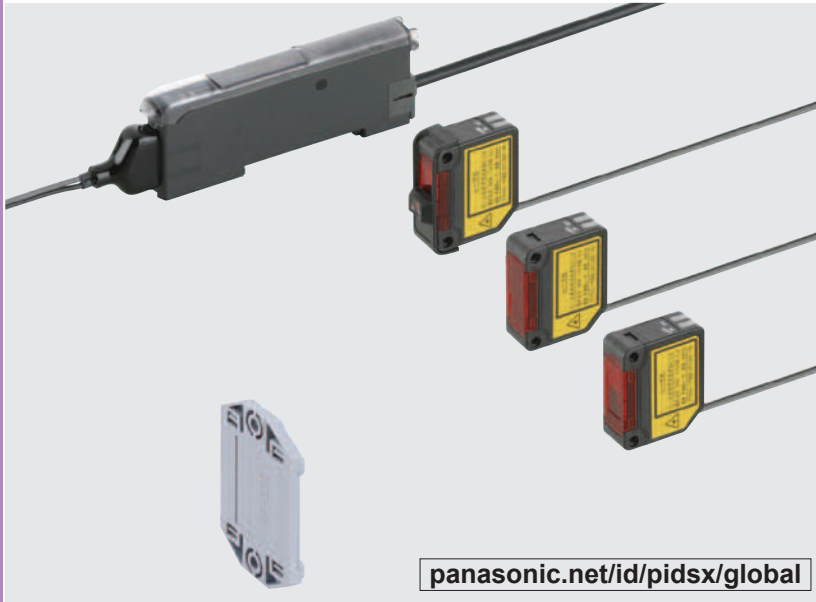

panasonic.net/id/pidsx/global

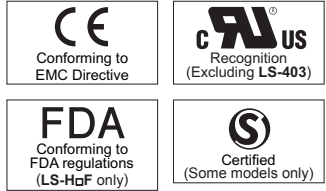

These products are Class 2 (LS-H□-A: Class 1) laser in compliance with IEC / JIS / GB standards and FDA* regulations. Do not look at the laser beam directly or through optical system such as a lens.

*This product complies with 21 CFR 1040.10 Laser Notice No. 50, dated July 26, 2001, issued by CDRH (Center for Devices and Radiological Health) under the FDA (Food and Drug Administration).

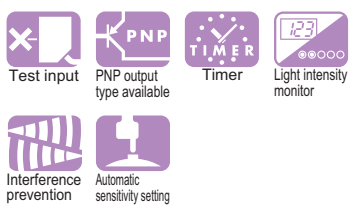

User-friendly, high precision laser sensing!

We offer 6 types of laser sensor heads for various applications

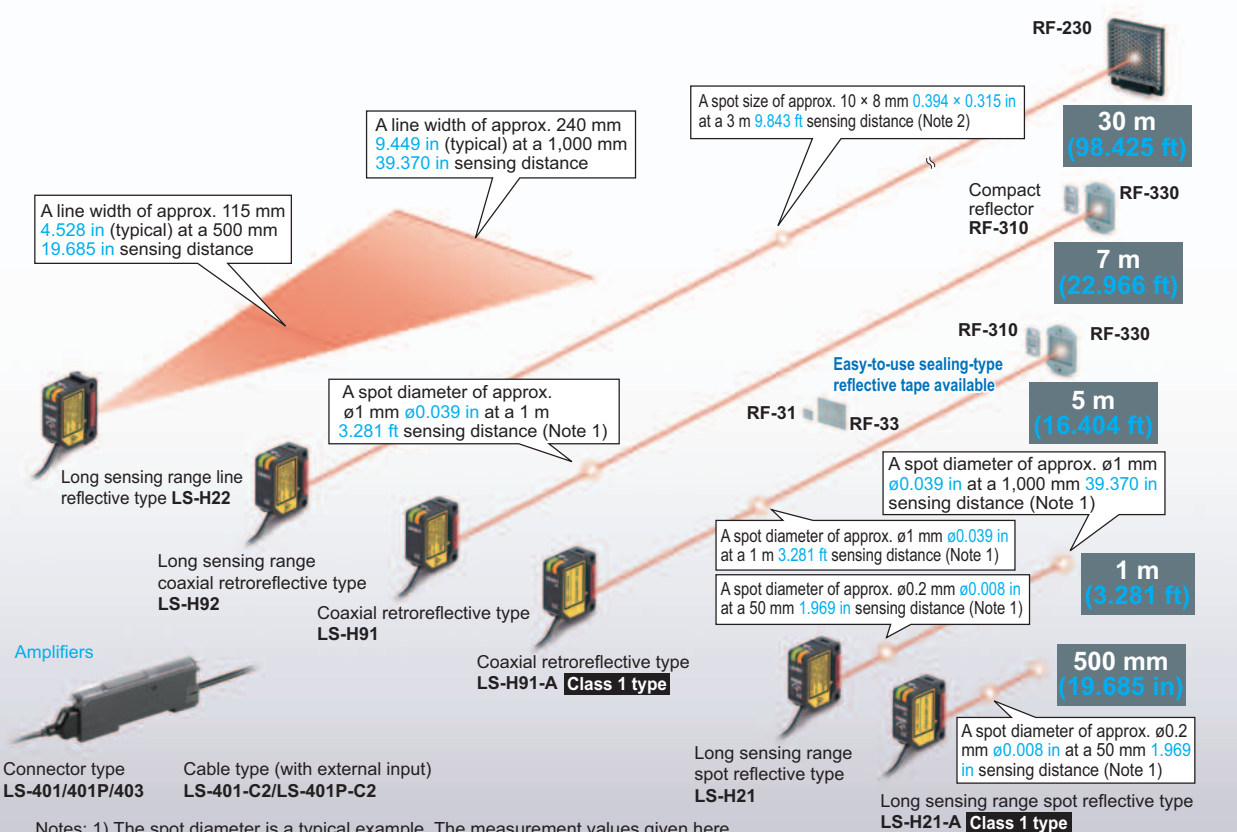

Notes: 1) The spot diameter is a typical example. The measurement values given here were determined with a center light intensity of 1/e² (13.5 %).
2) This is the reference value from visual observation.

APPLICATIONS

Detecting objects with a complex shape

Its linear sensing area enables more stable detection of objects with complex shapes.

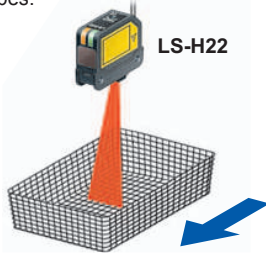

Detecting the remaining amount of sheet rolls

The coaxial retroreflective sensor with a spot diameter of approx. $\phi 1 \text{ mm } \phi 0.039 \text{ in}$ (at a 1 m 3.281 ft sensing distance), can measure amounts remaining on sheet rolls with high precision.

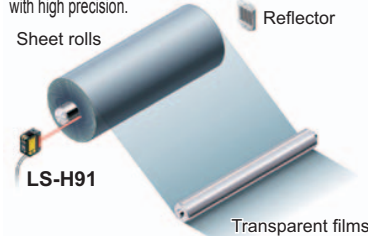

Detecting electronic component pins

Because its spot shape can be adjusted in accordance with the object, it can be easily set to detect even the minutest object from a remote location.

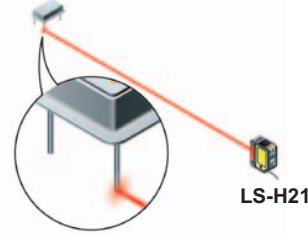

NOTE: The applications given in this catalog are examples for reference only. Stable sensing may not be possible under certain setup conditions and environmental conditions, so be sure to check the actual sensor before use.

Long sensing range spot reflective type

Long sensing range line reflective type

Industry standard mounting pitch

The mounting pitch for sensor heads is 25.4 mm 1.000 in, the same industry standard as the **CX-400** series general purpose photoelectric sensors. Hence, existing mounting brackets can be used even when replacing general purpose sensors with laser sensors.

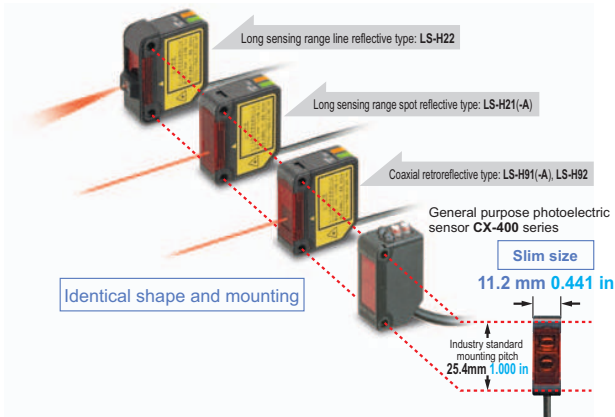

Easy and accurate adjustments

A spot-size adjuster is built into the back of the sensor head allowing the user to adjust the sensor easily while viewing the spot. The adjuster is adjustable with a screwdriver to avoid accidents during maintenance or any other time the sensors are handled.

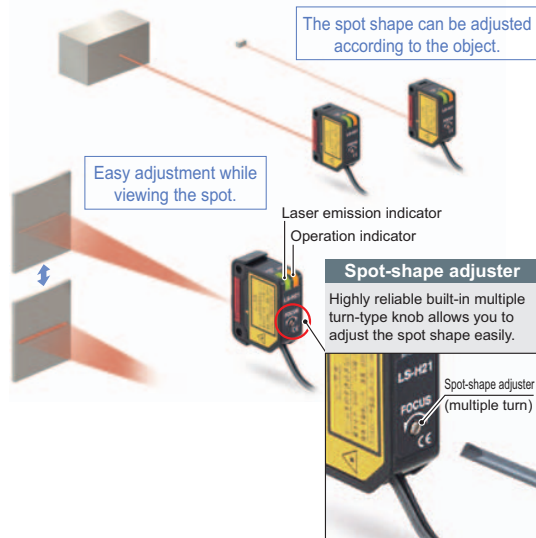

Line-up of FDA / IEC / JIS Class 1 type **LS-H91(F)-A, LS-H21(F)-A**

Visible light spot using the Class 1 type. This makes beam axis alignment much easier.

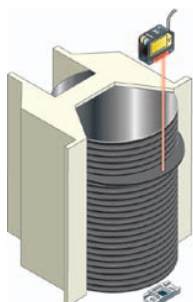

Sensor mounting bracket for beam axis alignment is available **MS-CX-11**

It is possible to make a minor adjustment for the bracket by 4 degrees up, down, right or left, even after setting up the sensor. The bracket can be mounted in both longitudinal and lateral directions.

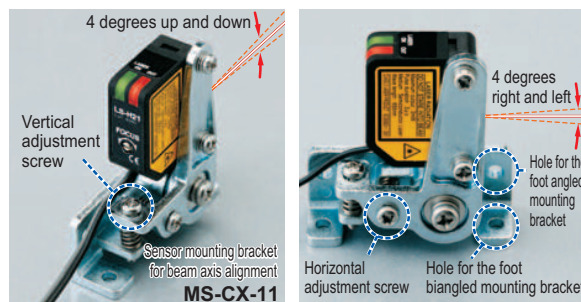

- FIBER SENSORS
- LASER SENSORS**
- PHOTOELECTRIC SENSORS
- MICRO PHOTOELECTRIC SENSORS
- AREA SENSORS
- LIGHT CURTAINS / SAFETY COMPONENTS
- PRESSURE / FLOW SENSORS
- INDUCTIVE PROXIMITY SENSORS
- PARTICULAR USE SENSORS
- SENSOR OPTIONS
- SIMPLE WIRE-SAVING UNITS
- WIRE-SAVING SYSTEMS
- MEASUREMENT SENSORS
- STATIC ELECTRICITY PREVENTION DEVICES
- LASER MARKERS
- PLC
- HUMAN MACHINE INTERFACES
- ENERGY CONSUMPTION VISUALIZATION COMPONENTS
- FA COMPONENTS
- MACHINE VISION SYSTEMS
- UV CURING SYSTEMS

Selection Guide
Amplifier Built-in
Amplifier-separated

LS-500
LS-400

- FIBER SENSORS
- LASER SENSORS**
- PHOTOELECTRIC SENSORS
- MICRO PHOTOELECTRIC SENSORS
- AREA SENSORS
- LIGHT CURTAINS / SAFETY COMPONENTS
- PRESSURE / FLOW SENSORS
- INDUCTIVE PROXIMITY SENSORS
- PARTICULAR USE SENSORS
- SENSOR OPTIONS
- SIMPLE WIRE-SAVING UNITS
- WIRE-SAVING SYSTEMS
- MEASUREMENT SENSORS
- STATIC ELECTRICITY PREVENTION DEVICES
- LASER MARKERS
- PLC
- HUMAN MACHINE INTERFACES
- ENERGY CONSUMPTION VISUALIZATION COMPONENTS
- FA COMPONENTS
- MACHINE VISION SYSTEMS
- UV CURING SYSTEMS

Easy setting, dual display

Equipped with 2 large 4-digit digital displays. While checking the current incident light intensity (red display), the optimal threshold value (green display) can be set easily.



2 switches enable simple operation

Only two switches, the large MODE key and the large jog switch, are required for operation.



MODE Pressing the switch selects or cancels the operating mode

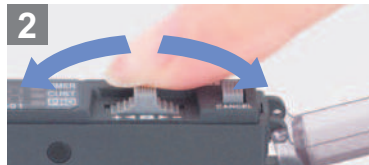

Moving the switch from side to side allows items to be selected



PUSH Pressing the switch then confirms the selected setting

Wiring and space saving

The quick-connection cables enable reductions in wiring. (connector type)
 The connections and man-hours for the relay terminal setup can be reduced and valuable space is saved.
 Also, **LS-400** series sensors can be connected side-by-side, up to 16 units, with a connector type of **FX-500/300** series digital fiber sensors and **DPS-400** series digital pressure sensors.

Note: Because the transmission method varies depending on the amplifiers, check the instruction manual for the amplifiers when connecting them.

Digital fiber sensor **FX-500/300** series
 Digital pressure sensor **DPS-400** series



Up to 16 units can be connected together

Threshold tracking function saves maintenance time

LS-403

This function seeks changes in the light emitting amount resulting from changes in the environment over long periods (such as dust levels), so that the incident light intensity can be checked at desired intervals and the threshold values can be reset automatically. This helps to reduce the man-hours for maintenance.

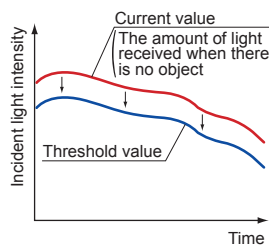

Amplifier with upper communication function is available.

LS-403

The amplifier with upper communication function **LS-403** enables data communication through CC-Link / DeviceNet / EtherCAT by using with a communication unit for open network (**SC-GU2-C / SC-GU3** series) together. As for communication unit for open network, other than **LS-403**, laser sensor **LS-501**, digital fiber sensors **FX-501/502/301/305** and digital pressure sensors **DPS-401/402** are also connectable. It is possible to carry out batch data communication.

* Please refer to communication unit for open network for details.

Selection Guide
Amplifier Built-in
Amplifier-separated

LS-500
LS-400

4 new modes enabling wide array of sensing

Hysteresis mode

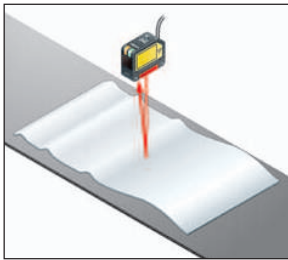

By adjusting the hysteresis, convexo-concave parts of uneven objects can be cancelled enabling more stable sensing.

Window comparator mode

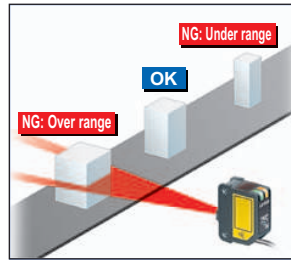

The sensor judges any object outside the range of incident light intensity established by two set threshold values.

2 independent output modes

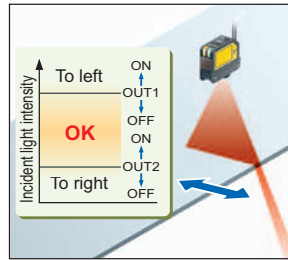

By combining two outputs, wide array of control is possible, allowing you to detect meandering objects, for example.

Differential sensing mode

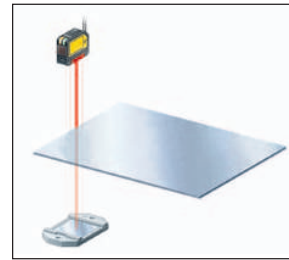

Only rapid changes in light received are detected, which enable the edge of glass, etc. to be detected accurately. Optimal for positioning.

MODE NAVI customized function

Frequently used functions such as response time, M.G.S. function, data bank load, emission halt function and D-CODE values can be stored in CUSTOM mode. The settings are changed easily.

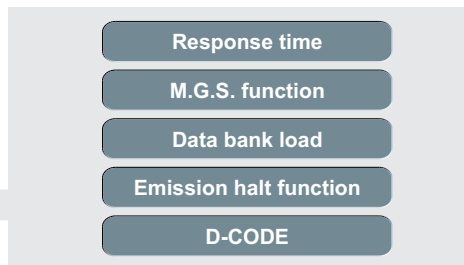

Accurately sense the minutest variations (M.G.S. function)

When sensing at close range or when the target objects are transparent or minute, adjust the sensor receiving sensitivity to one of 3 levels (U-LG mode: 4 levels) for the optimal setting. In addition, changing the receiving sensitivity will not effect the response time.

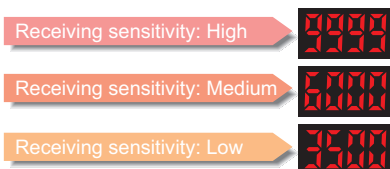

The sensitivity can be changed without changing the response time.

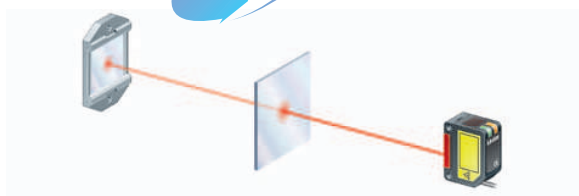

Emission halt function

Using the emission halt function, the laser beam can be stopped via external input, e.g. when a spot appears within the visual range of an image processor.

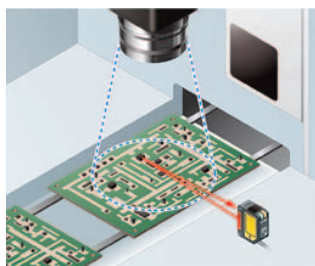

Cable type allows external input

The LS-401-C2 cable-type amplifier is equipped with an external input wire (5-core). It is ideal to use the laser sensor at places where external teaching or laser light emission halting is to be carried out, or at the places where the laser sensor is to be used separately.

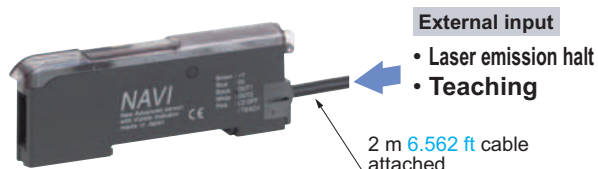

Interference prevention function

The automatic interference prevention function prevents against interference among up to 4 sensors.

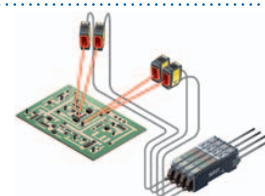

Setting conditions viewed at a glance (D-CODE)

The amplifier setting is shown as an 8-digit code. Handy for remote indications and follow-ups.

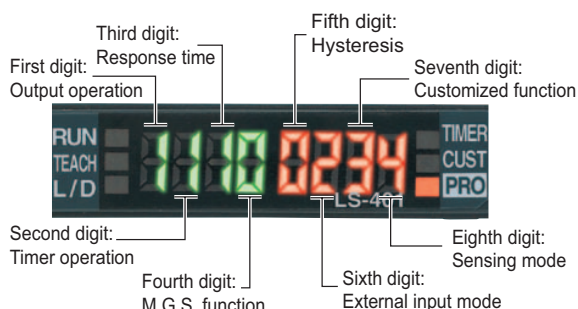

FIBER SENSORS

LASER SENSORS

PHOTOELECTRIC SENSORS

MICRO PHOTOELECTRIC SENSORS

AREA SENSORS

LIGHT CURTAINS / SAFETY COMPONENTS

PRESSURE / FLOW SENSORS

INDUCTIVE PROXIMITY SENSORS

PARTICULAR USE SENSORS

SENSOR OPTIONS

SIMPLE WIRE-SAVING UNITS

WIRE-SAVING SYSTEMS

MEASUREMENT SENSORS

STATIC ELECTRICITY PREVENTION DEVICES

LASER MARKERS

PLC

HUMAN MACHINE INTERFACES

ENERGY CONSUMPTION VISUALIZATION COMPONENTS

FA COMPONENTS

MACHINE VISION SYSTEMS

UV CURING SYSTEMS

Selection Guide

Amplifier Built-in

Amplifier-separated

LS-500

LS-400

ORDER GUIDE

Sensor heads

Type	Appearance	Model No.	Conforming standards	Sensing range	■ : U-LG ■ : STD ■ : FAST ■ : H-SP
Coaxial retroreflective		Class 2	LS-H92	IEC / JIS / GB	■ 0.2 to 30 m 0.656 to 98.425 ft (Note 2) ■ 0.2 to 20 m 0.656 to 65.617 ft (Note 2) ■ 0.2 to 10 m 0.656 to 32.808 ft (Note 2) ■ 0.2 to 10 m 0.656 to 32.808 ft (Note 2)
			LS-H92F (Note 1)	FDA / IEC / JIS	
		Class 1	LS-H91	IEC / JIS / GB	■ 0.1 to 7 m 0.328 to 22.966 ft (Note 2) ■ 0.1 to 5 m 0.328 to 16.404 ft (Note 2) ■ 0.1 to 3 m 0.328 to 9.843 ft (Note 2) ■ 0.1 to 3 m 0.328 to 9.843 ft (Note 2)
			LS-H91F (Note 1)	FDA / IEC / JIS	
			LS-H91-A	IEC / JIS / GB	■ 0.1 to 5 m 0.328 to 16.404 ft (Note 2) ■ 0.1 to 3 m 0.328 to 9.843 ft (Note 2) ■ 0.1 to 1 m 0.328 to 3.281 ft (Note 2) ■ 0.1 to 1 m 0.328 to 3.281 ft (Note 2)
			LS-H91F-A (Note 1)	FDA / IEC / JIS	
Diffuse reflective	Long sensing range spot reflective	Class 2	LS-H21	IEC / JIS / GB	■ 30 to 1,000 mm 1.181 to 39.370 in ■ 30 to 500 mm 1.181 to 19.685 in ■ 30 to 300 mm 1.181 to 11.811 in ■ 30 to 300 mm 1.181 to 11.811 in
			LS-H21F (Note 1)	FDA / IEC / JIS	
		Class 1	LS-H21-A	IEC / JIS / GB	■ 30 to 500 mm 1.181 to 19.685 in ■ 30 to 250 mm 1.181 to 9.843 in ■ 30 to 150 mm 1.181 to 5.906 in ■ 30 to 150 mm 1.181 to 5.906 in
			LS-H21F-A (Note 1)	FDA / IEC / JIS	
	Long sensing range line reflective	Class 2	LS-H22 (Note 3)	IEC / JIS / GB	■ 30 to 1,000 mm 1.181 to 39.370 in ■ 30 to 500 mm 1.181 to 19.685 in ■ 30 to 300 mm 1.181 to 11.811 in ■ 30 to 300 mm 1.181 to 11.811 in
			LS-H22F (Note 1, 3)	FDA / IEC / JIS	

NOTE: Mounting bracket is not supplied with the sensor head. Please select from the range of optional sensor head mounting brackets.

- Notes: 1) This product complies with 21 CFR 1040.10 Laser Notice No. 50, dated July 26, 2001, issued by CDRH (Center for Devices and Radiological Health) under the FDA (Food and Drug Administration). For details, refer to the Laser Notice No. 50.
 2) The sensing range is the value for the **RF-330 [RF-230 for the LS-H92(F)]** reflector. In addition, the sensing range is the possible setting range for the reflector. The sensor can detect an object less than 0.1 m **0.328 ft [LS-H92(F): 0.2 m 0.656 ft]** away. Note that if there are white papers or specular objects near the sensor head, reflected light from these objects may be received. In such cases, use the M.G.S. function of the amplifier unit to change the response time or incident light sensitivity.
 3) **LS-H22(F)** is the model No. for **LS-H21(F)** long sensing range spot reflective type sensor head combined with the **LS-MR1** lens attachment for line reflective type sensor head. Hence, **LS-H21(F)** appears on the sensor head itself.

5 m 16.404 ft cable length type

5 m **16.404 ft** cable length type (standard: 2 m **6.562 ft**) is also available. When ordering this type, suffix **"-C5"** to the model No.

- **LS-H91-C5**
- **LS-H91-A-C5**
- **LS-H21-C5**
- **LS-H22-C5**

Package without reflector

The **LS-H91(F)**, **LS-H91(F)-A** and **LS-H92(F)** are also available without the reflector (**RF-330** or **RF-230**). When ordering this type, suffix **"-Y"** to the model No.



- **LS-H92-Y**
- **LS-H92F-Y**
- **LS-H91-Y**
- **LS-H91F-Y**
- **LS-H91-A-Y**
- **LS-H91F-A-Y**

LS-500

LS-400

ORDER GUIDE

Amplifiers

Type	Appearance	Model No.	Output	Connection method
Connector type		LS-401 (Note 1)	NPN open-collector transistor two outputs	Use quick-connection cable (4-core) (optional)
		LS-401P	PNP open-collector transistor two outputs	
		LS-403	NPN open-collector transistor two outputs	
Cable type (With external input)		LS-401-C2 (Note 1)	NPN open-collector transistor two outputs	2 m 6.562 ft cabtyre cable (5-core) included Cable outer diameter: $\phi 3.7$ mm $\phi 0.146$ in
		LS-401P-C2	PNP open-collector transistor two outputs	

Notes: 1) Obtained Korea's S-mark certification.
2) For upper communication, a communication unit for open network (**SC-GU2-C / SC-GU3** series) is needed separately.

Quick-connection cables Quick-connection cable is not supplied with the connector type amplifier. Please order it separately.

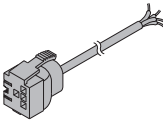
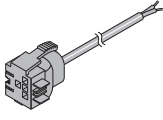
Type	Appearance	Model No.	Description
Main cable (4-core)		CN-74-C1	Length: 1 m 3.281 ft
		CN-74-C2	Length: 2 m 6.562 ft
		CN-74-C5	Length: 5 m 16.404 ft
Sub cable (2-core)		CN-72-C1	Length: 1 m 3.281 ft
		CN-72-C2	Length: 2 m 6.562 ft
		CN-72-C5	Length: 5 m 16.404 ft

End plates End plates are not supplied with the amplifier. Please order them separately when the amplifiers are mounted in cascade.

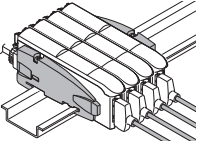
Type	Model No.	Description
	MS-DIN-E	When cascading multiple amplifiers, or when it moves depending on the way it is installed on a DIN rail, these end plates clamp amplifiers into place on both sides. Make sure to use end plates when cascading multiple amplifiers together. Two pcs. per set

Accessories

- **RF-330** (Reflector)

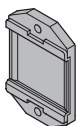

- **RF-230** (Reflector)

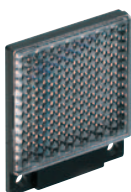

Note: **LS-H92(F)** only

- **CN-EP1** (Connector for amplifier)

5 pcs. per set (Note)

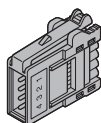

Note: One is attached to each sensor head according to standard.

- **LS-MR1** (Lens attachment for line reflective type)

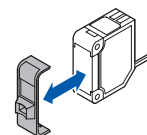

FIBER SENSORS

LASER SENSORS

PHOTO-ELECTRIC SENSORS

MICRO PHOTO-ELECTRIC SENSORS

AREA SENSORS

LIGHT CURTAINS / SAFETY COMPONENTS

PRESSURE / FLOW SENSORS

INDUCTIVE PROXIMITY SENSORS

PARTICULAR USE SENSORS

SENSOR OPTIONS

SIMPLE WIRE-SAVING UNITS

WIRE-SAVING SYSTEMS

MEASUREMENT SENSORS

STATIC ELECTRICITY PREVENTION DEVICES

LASER MARKERS

PLC

HUMAN MACHINE INTERFACES

ENERGY CONSUMPTION VISUALIZATION COMPONENTS

FA COMPONENTS

MACHINE VISION SYSTEMS

UV CURING SYSTEMS

Selection Guide

Amplifier Built-in

Amplifier-separated

LS-500

LS-400

OPTIONS

- FIBER SENSORS
- LASER SENSORS
- PHOTO-ELECTRIC SENSORS
- MICRO PHOTO-ELECTRIC SENSORS
- AREA SENSORS
- LIGHT CURTAINS/SAFETY COMPONENTS
- PRESSURE / FLOW SENSORS
- INDUCTIVE PROXIMITY SENSORS
- PARTICULAR USE SENSORS
- SENSOR OPTIONS
- SIMPLE WIRE-SAVING UNITS
- WIRE-SAVING SYSTEMS
- MEASUREMENT SENSORS
- STATIC ELECTRICITY PREVENTION DEVICES
- LASER MARKERS
- PLC
- HUMAN MACHINE INTERFACES
- ENERGY CONSUMPTION VISUALIZATION COMPONENTS
- FA COMPONENTS
- MACHINE VISION SYSTEMS
- UV CURING SYSTEMS

Designation	Model No.	Description
Sensor head mounting bracket	MS-CX-1	Foot angled mounting bracket
	MS-CX-2	Foot biangled mounting bracket Flat mounting possible to avoid obstructions caused by the height of the sensor.
	MS-CX-3	Back angled mounting bracket
	MS-CX-4	Protective mounting bracket Protects sensors preventing beam axis displacement due to shocks.
Sensor mounting bracket for beam axis alignment	MS-CX-11	Mounting bracket that makes fine beam axis alignment possible after setting the sensor head. Adjustment angle: up and down, right and left: 4 degrees Mounting directions: two directions, vertical and horizontal
Universal sensor mounting stand (Note 1)	MS-AJ1	Horizontal mounting type
	MS-AJ2	Vertical mounting type
	MS-AJ1-A	Horizontal mounting type
	MS-AJ2-A	Vertical mounting type
Amplifier mounting bracket	MS-DIN-2	Mounting bracket for amplifier
Reflector mounting bracket	MS-RF23	Mounting bracket for RF-230
Amplifier protection seal	FX-MB1	10 sets of 2 communication window seals and 1 connector seal Communication window seal: It prevents malfunction due to transmission signal from another amplifier, as well as, prevents effect on another amplifier. Connector seal: It prevents contact of any metal, etc., with the pins of the quick-connection cable.
Reflector	RF-310	For coaxial retroreflective type Compact reflector
Reflective tape	RF-33	For coaxial retroreflective type Size: 25.2 × 27.8 × t 0.4 mm 0.992 × 1.094 × t 0.016 in
	RF-31	For coaxial retroreflective type Size: 9.2 × 9.2 × t 0.4 mm 0.362 × 0.362 × t 0.016 in
Bank selection unit (Note 2)	FX-CH	NPN input type
	FX-CH-P	PNP input type

Notes: 1) Refer to p.979 the universal sensor mounting stand **MS-AJ** series.
2) Please see the website for details of the bank selection unit **FX-CH**.

Universal sensor mounting stand

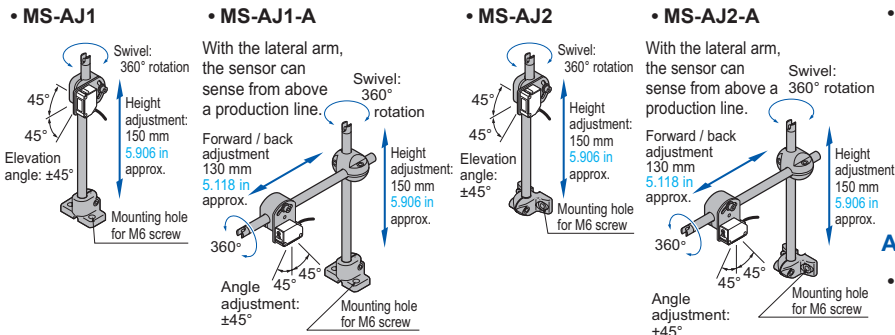

Reflector

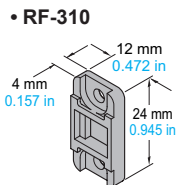

Reflective tape

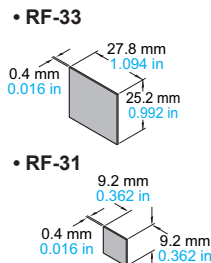

Sensor head mounting bracket

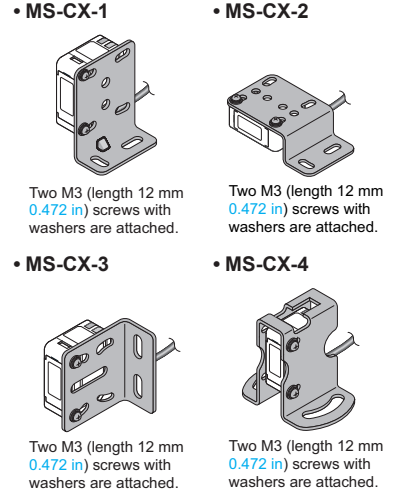

Sensor mounting bracket for beam axis alignment

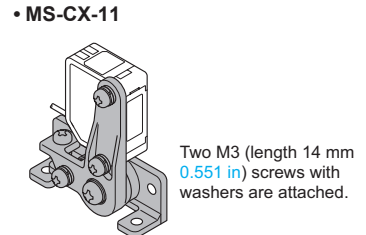

Amplifier mounting bracket

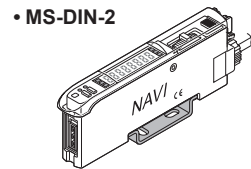

Reflector mounting bracket

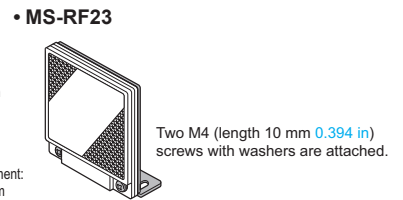

Amplifier protection seal

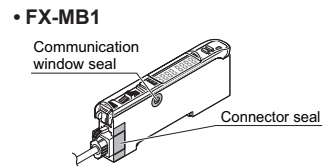

Bank selection unit

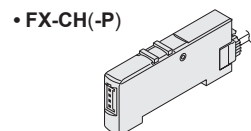

SPECIFICATIONS

Sensor heads

Item	Model No.	IEC / JIS / GB standards conforming type	Coaxial retroreflective			Diffuse reflective		
			Class 2		Class 1	Long sensing range spot reflective		Long sensing range line reflective
			LS-H92	LS-H91	LS-H91-A	Class 2	Class 1	
		FDA / IEC / JIS standards conforming type (Note 2)	LS-H92F	LS-H91F	LS-H91F-A	LS-H21F	LS-H21F-A	LS-H22F(Note 3)
Applicable amplifiers		LS-401(P), LS-401(P)-C2, LS-403						
Sensing range	U-LG mode	0.2 to 30 m 0.656 to 98.425 ft (Note 4)	0.1 to 7 m 0.328 to 22.966 ft (Note 4)	0.1 to 5 m 0.328 to 16.404 ft (Note 4)	30 to 1,000 mm 1.181 to 39.370 in	30 to 500 mm 1.181 to 19.685 in	30 to 1,000 mm 1.181 to 39.370 in	
	STD mode	0.2 to 20 m 0.656 to 65.617 ft (Note 4)	0.1 to 5 m 0.328 to 16.404 ft (Note 4)	0.1 to 3 m 0.328 to 9.843 ft (Note 4)	30 to 500 mm 1.181 to 19.685 in	30 to 250 mm 1.181 to 9.843 in	30 to 500 mm 1.181 to 19.685 in	
	FAST mode	0.2 to 10 m 0.656 to 32.808 ft (Note 4)	0.1 to 3 m 0.328 to 9.843 ft (Note 4)	0.1 to 1 m 0.328 to 3.281 ft (Note 4)	30 to 300 mm 1.181 to 11.811 in	30 to 150 mm 1.181 to 5.906 in	30 to 300 mm 1.181 to 11.811 in	
	H-SP mode							
Operation indicator		Orange LED (lights up when the amplifier output is ON)						
Laser emission indicator		Green LED (lights up during laser emission)						
Spot-shape adjuster		—			Multi-turn adjuster			
Environmental resistance	Protection	IP40 (IEC)						
	Ambient temperature	-10 to +55 °C +14 to +131 °F (No dew condensation or icing allowed), Storage: -20 to +70 °C -4 to +158 °F						
	Ambient humidity	35 to 85 % RH, Storage: 35 to 85 % RH						
	Ambient illuminance	Incandescent light: 3,000 lx at the light-receiving face						
	Voltage withstandability	1,000 V AC for one min. between all supply terminals connected together and enclosure						
	Insulation resistance	20 MΩ, or more, with 250 V DC megger between all supply terminals connected together and enclosure						
	Vibration resistance	10 to 500 Hz frequency, 1.5 mm 0.059 in (10 G max.) amplitude in X, Y and Z directions for two hours each						
	Shock resistance	100 m/s ² acceleration (10 G approx.) in X, Y and Z directions for three times each						
Emitting element	IEC / JIS / GB standards conforming type	Red semiconductor laser, Class 2 (IEC / JIS / GB) (Max. output: 3 mW Peak emission wavelength: 655 nm 0.026 mil)	Red semiconductor laser, Class 1 (IEC / JIS / GB) (Max. output: 1 mW Peak emission wavelength: 655 nm 0.026 mil)	Red semiconductor laser, Class 2 (IEC / JIS / GB) (Max. output: 3 mW Peak emission wavelength: 655 nm 0.026 mil)	Red semiconductor laser, Class 1 (IEC / JIS / GB) (Max. output: 1 mW Peak emission wavelength: 655 nm 0.026 mil)	Red semiconductor laser, Class 2 (IEC / JIS / GB) (Max. output: 3 mW Peak emission wavelength: 655 nm 0.026 mil)	Red semiconductor laser, Class 2 (IEC / JIS / GB) (Max. output: 3 mW Peak emission wavelength: 655 nm 0.026 mil)	
	FDA / IEC / JIS standards conforming type (Note 2)	Red semiconductor laser, Class 2 (FDA / IEC / JIS) (Max. output: 3 mW Peak emission wavelength: 655 nm 0.026 mil)	Red semiconductor laser, Class 1 (FDA / IEC / JIS) (Max. output: 1 mW Peak emission wavelength: 655 nm 0.026 mil)	Red semiconductor laser, Class 2 (FDA / IEC / JIS) (Max. output: 3 mW Peak emission wavelength: 655 nm 0.026 mil)	Red semiconductor laser, Class 1 (FDA / IEC / JIS) (Max. output: 1 mW Peak emission wavelength: 655 nm 0.026 mil)	Red semiconductor laser, Class 2 (FDA / IEC / JIS) (Max. output: 3 mW Peak emission wavelength: 655 nm 0.026 mil)	Red semiconductor laser, Class 2 (FDA / IEC / JIS) (Max. output: 3 mW Peak emission wavelength: 655 nm 0.026 mil)	
Material		Enclosure: PBT (Mounting part: PEI), Lens cover: Acrylic						
Cable		0.1 mm ² , single core two parallel shielded cables, 2 m 6.562 ft long (Connector for amplifier attached) (Note 5)						
Weight		Net weight: 30 g approx. Gross weight: 40 g approx.	Net weight: 30 g approx. Gross weight: 45 g approx.	Net weight: 30 g approx. Gross weight: 40 g approx.	Net weight: 30 g approx. Gross weight: 40 g approx.	Net weight: 35 g approx. Gross weight: 45 g approx.		
Accessories		RF-230 (Reflector): 1 pc. Warning label: 1 set (Labels are written in Japanese, English and Chinese for compliance with various standards.)	RF-330 (Reflector): 1 pc. Warning label: 1 set (Labels are written in Japanese, English and Chinese for compliance with various standards.)	RF-330 (Reflector): 1 pc. Explanation label: 1 set (Labels are written in Japanese and Chinese for compliance with various standards.)	Warning label: 1 set (Labels are written in Japanese, English and Chinese for compliance with various standards.)	Explanation label: 1 set (Labels are written in Japanese and Chinese for compliance with various standards.)	LS-MR1 (Lens attachment) for line reflective : 1 pc. Warning label: 1 set (Labels are written in Japanese, English and Chinese for compliance with various standards.)	

- Notes: 1) Where measurement conditions have not been specified precisely, the conditions used were an ambient temperature of +23 °C +73.4 °F.
 2) This product complies with 21 CFR 1040.10 Laser Notice No. 50, dated July 26, 2001, issued by CDRH (Center for Devices and Radiological Health) under the FDA (Food and Drug Administration). For details, refer to the Laser Notice No. 50.
 3) **LS-H22(F)** is the set model No. for **LS-H21(F)** long sensing range spot reflective type sensor head combined with the **LS-MR1** lens attachment for line reflective type. Hence, **LS-H21(F)** appears on the sensor head itself.
 4) The sensing range is the value for the **RF-330 [RF-230 for the LS-H92(F)]** reflector. In addition, the sensing range is the possible setting range for the reflector. The sensor can detect an object less than 0.1 m 0.328 ft [**LS-H92(F)**: 0.2 m 0.656 ft] away. Note that if there are white papers or specular objects near the sensor head, reflected light from these objects may be received. In such cases, use the M.G.S. function of the amplifier unit to change the response time or incident light sensitivity.
 5) Cable cannot be extended.

FIBER SENSORS

LASER SENSORS

PHOTO-ELECTRIC SENSORS

MICRO PHOTO-ELECTRIC SENSORS

AREA SENSORS

LIGHT CURTAINS / SAFETY COMPONENTS

PRESSURE / FLOW SENSORS

INDUCTIVE PROXIMITY SENSORS

PARTICULAR USE SENSORS

SENSOR OPTIONS

SIMPLE WIRE-SAVING UNITS

WIRE-SAVING SYSTEMS

MEASUREMENT SENSORS

STATIC ELECTRICITY PREVENTION DEVICES

LASER MARKERS

PLC

HUMAN MACHINE INTERFACES

ENERGY CONSUMPTION VISUALIZATION COMPONENTS

FA COMPONENTS

MACHINE VISION SYSTEMS

UV CURING SYSTEMS

Selection Guide

Amplifier Built-in

Amplifier Separated

LS-500

LS-400

SPECIFICATIONS

Amplifiers

Item	Model No.	Type	Connector type		Cable type
				With upper communication function	
		NPN output	LS-401	LS-403	LS-401-C2
		PNP output	LS-401P	—	LS-401P-C2
Supply voltage		12 to 24 V DC $\pm 10\%$ Ripple P-P 10% or less			
Power consumption		Normal operation: 950 mW or less (Current consumption 40 mA or less at 24 V supply voltage) ECO mode: 780 mW or less (Current consumption 33 mA or less at 24 V supply voltage)			
Outputs (Output 1, Output 2)		<p><NPN output type> NPN open-collector transistor</p> <ul style="list-style-type: none"> Maximum sink current: 100 mA (LS-401) (Note 2), 50 mA (LS-403) (Note 3) Applied voltage: 30 V DC or less (between output and 0 V) Residual voltage: 1.5 V or less at [100 mA (Note 2) sink current at 60 mA (Note 3) sink current (LS-403)] <p><PNP output type> PNP open-collector transistor</p> <ul style="list-style-type: none"> Maximum source current: 100 mA (Note 2) Applied voltage: 30 V DC or less (between output and +V) Residual voltage: 1.5 V or less [at 100 mA (Note 2) source current] 			
Output operation		Selectable either Light-ON or Dark-ON, with jog switch			
Short-circuit protection		Incorporated			
Response time		80 μ s or less (H-SP), 150 μ s or less (FAST), 500 μ s or less (STD), 4 ms or less (U-LG) selectable with jog switch			
External input (Laser emission halt) (Full-auto teaching / Limit teaching)		<p><NPN output type> NPN non-contact input</p> <ul style="list-style-type: none"> Signal condition High: +5 V to +V or open, Low: 0 to +2 V (source current 0.5 mA or less) Input impedance: 10 kΩ approx. <p><PNP output type> PNP non-contact input</p> <ul style="list-style-type: none"> Signal condition High: +4 V to +V (sink current 3 mA or less) Low: 0 to +0.6 V or open Input impedance: 10 kΩ approx. 			
Operation indicator		Orange LED (lights up when output 1 and output 2 are ON)			
Laser emission indicator		Green LED (lights up during laser emission)			
Select indicator		Yellow LED (lights up when either output 1 or output 2 is selected)			
MODE indicator		RUN: Green LED, TEACH • L/D • TIMER • CUST • PRO: Yellow LED			
Digital display		4 digit (green) + 4 digit (red) LED display			
Sensitivity setting		Normal mode: 2-level teaching / Limit teaching / Full-auto teaching / Manual adjustment Window comparator mode: Teaching (1-level, 2-level, 3-level) / Manual adjustment Hysteresis mode: Teaching (1-level, 2-level, 3-level) / Manual adjustment Differential mode: 5-level settings (LS-403 : 8-level settings)			
Fine sensitivity adjustment function		Incorporated			
Timer function		Incorporated with variable ON-delay / OFF-delay / ONE SHOT timer, switchable either effective or ineffective.			
Timer period		1 to 9,999 ms approx.	0.5 ms approx. 1 to 9,999 ms approx.	1 to 9,999 ms approx.	
Automatic interference prevention function		Incorporated [Up to four sets of sensor heads can be mounted close together. (However, LS-401 is disabled when in H-SP mode, up to two sets of LS-403 can be mounted close together when in H-SP mode)]			
Environmental resistance	Ambient temperature	-10 to +55 °C +14 to +131 °F (if 4 to 7 units are mounted close together: -10 to +50 °C +14 to +122 °F, if 8 to 16 units are mounted close together: -10 to +45 °C +14 to +113 °F) (No dew condensation or icing allowed), Storage: -20 to +70 °C 4 to +158 °F			
	Ambient humidity	35 to 85 % RH, Storage: 35 to 85 % RH			
	Voltage withstandability	1,000 V AC for one min. between all supply terminals connected together and enclosure			
	Insulation resistance	20 M Ω , or more, with 250 V DC megger between all supply terminals connected together and enclosure			
	Vibration resistance	10 to 150 Hz frequency, 0.75 mm 0.030 in amplitude in X, Y and Z directions for two hours each			
	Shock resistance	98 m/s ² acceleration (10 G approx.) in X, Y and Z directions for five times each			
Material		Enclosure: Heat-resistant ABS, Transparent cover: Polycarbonate, Push button switch: Acrylic, Jog switch: ABS			
Cable		— (Note 4)		0.15 mm ² 5-core cabtyre cable, 2 m 6.562 ft long	
Cable extension		Extension up to total 100 m 328.084 ft is possible with 0.3 mm ² , or more, cable.			
Weight		Net weight: 15 g approx., Gross weight: 20 g approx.		Net weight: 65 g approx., Gross weight: 75 g approx.	

- Notes: 1) Where measurement conditions have not been specified precisely, the conditions used were an ambient temperature of +23 °C +73.4 °F.
 2) In case of **LS-401(P)**, 50 mA if 5 to 8 amplifiers are connected in cascade, and 25 mA if 9 to 16 amplifiers are connected in cascade.
 3) In case of **LS-403**, 25 mA if 5 to 16 amplifiers are connected in cascade.
 4) The cable is not supplied as an accessory for connector type. Be sure to purchase the optional quick-connection cables given below.
 When connecting to **SC-GU2-C**, be sure to purchase the optional non-line connector.
 Main cable (4-core): **CN-74-C1** (cable length 1 m 3.281 ft), **CN-74-C2** (cable length 2 m 6.562 ft), **CN-74-C5** (cable length 5 m 16.404 ft)
 Sub cable (2-core): **CN-72-C1** (cable length 1 m 3.281 ft), **CN-72-C2** (cable length 2 m 6.562 ft), **CN-72-C5** (cable length 5 m 16.404 ft)
 Non-line connector: **CN-70**

I/O CIRCUIT AND WIRING DIAGRAMS

LS-401(-C2) LS-403

NPN output type

I/O circuit diagram

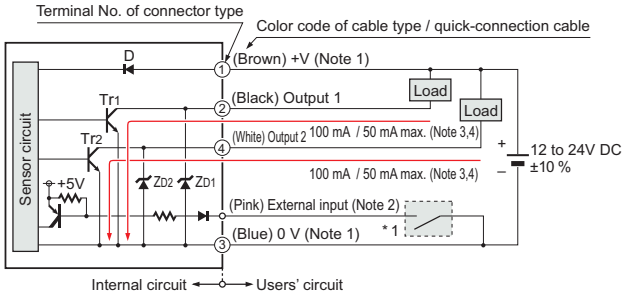

- Notes: 1) The quick-connection sub cable does not have +V (brown) and 0 V (blue). The power is supplied from the connector of the main cable.
 2) Connector type **LS-401/403** does not incorporate the external input.
 3) **LS-401(-C2)** is 100 mA max, however, **LS-401(-C2)** is 50 mA max. if 5 to 8 amplifiers are connected in cascade, and 25 mA max. if 9 to 16 amplifiers are connected in cascade.
 4) **LS-403** is 50 mA max, however, it is 25 mA max. if 5 to 16 amplifiers are connected in cascade.

* 1

Non-voltage contact or NPN open-collector transistor

- External input
 - High: +5 V to +V, or open
 - Low: 0 to +2 V (source current: 0.5 mA or less)
- Beam emission halts and teaching occurs when at Low.

Symbols ... D: Reverse supply polarity protection diode
 ZD1, ZD2: Surge absorption zener diode
 Tr1, Tr2: NPN output transistor

Wiring diagram

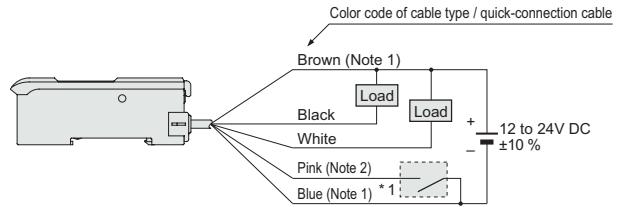

- Notes: 1) The quick-connection sub cable does not have brown lead wire and blue lead wire. The power is supplied from the connector of the main cable.
 2) The quick-connection cable does not have a pink lead wire.

Terminal layout of connector type

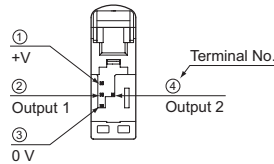

*** Connector for amplifier (CN-EP1) pin position**

Terminal No.	Connection cable
①	Conductor core wire: Brown
②	Shield wire
③	Conductor core wire: Yellow
④	Shield wire

Cable color: Gray (for terminals 1 and 2)
 Cable color: Black (for terminals 3 and 4)

LS-401P(-C2)

PNP output type

I/O circuit diagram

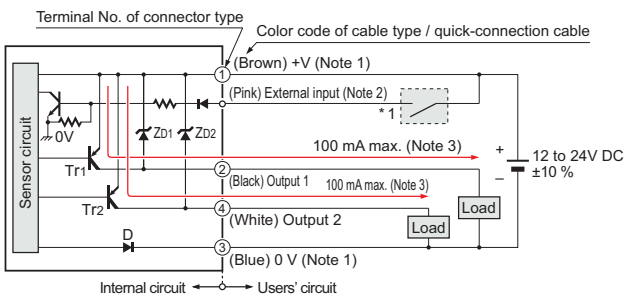

- Notes: 1) The quick-connection sub cable does not have +V (brown) and 0 V (blue). The power is supplied from the connector of the main cable.
 2) Connector type **LS-401P** does not incorporate the external input.
 3) **LS-401P** is 50 mA max. if 5 to 8 amplifiers are connected in cascade, and 25 mA max. if 9 to 16 amplifiers are connected in cascade.

* 1

Non-voltage contact or PNP open-collector transistor

- External input
 - High: +4 V to +V (sink current: 3 mA or less)
 - Low: 0 to +0.6 V, or open
- Beam emission halts and teaching occurs when at High.

Symbols ... D: Reverse supply polarity protection diode
 ZD1, ZD2: Surge absorption zener diode
 Tr1, Tr2: PNP output transistor

Wiring diagram

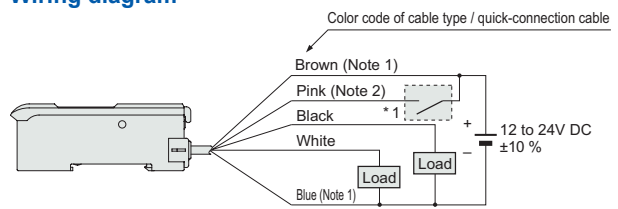

- Notes: 1) The quick-connection sub cable does not have brown lead wire and blue lead wire. The power is supplied from the connector of the main cable.
 2) The quick-connection cable does not have a pink lead wire.

Terminal layout of connector type

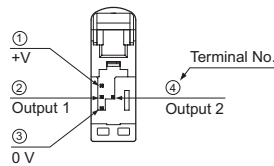

*** Connector for amplifier (CN-EP1) pin position**

Terminal No.	Connection cable
①	Conductor core wire: Brown
②	Shield wire
③	Conductor core wire: Yellow
④	Shield wire

Cable color: Gray (for terminals 1 and 2)
 Cable color: Black (for terminals 3 and 4)

FIBER SENSORS

LASER SENSORS

PHOTO-ELECTRIC SENSORS

MICRO PHOTO-ELECTRIC SENSORS

AREA SENSORS

LIGHT CURTAINS / SAFETY COMPONENTS

PRESSURE / FLOW SENSORS

INDUCTIVE PROXIMITY SENSORS

PARTICULAR USE SENSORS

SENSOR OPTIONS

SIMPLE WIRE-SAVING UNITS

WIRE-SAVING SYSTEMS

MEASUREMENT SENSORS

STATIC ELECTRICITY PREVENTION DEVICES

LASER MARKERS

PLC

HUMAN MACHINE INTERFACES

ENERGY CONSUMPTION VISUALIZATION COMPONENTS

FA COMPONENTS

MACHINE VISION SYSTEMS

UV CURING SYSTEMS

Selection Guide

Amplifier Built-in

Amplifier-separated

LS-500

LS-400

- FIBER SENSORS
- LASER SENSORS
- PHOTO-ELECTRIC SENSORS
- MICRO PHOTO-ELECTRIC SENSORS
- AREA SENSORS
- LIGHT CURTAINS / SAFETY COMPONENTS
- PRESSURE / FLOW SENSORS
- INDUCTIVE PROXIMITY SENSORS
- PARTICULAR USE SENSORS
- SENSOR OPTIONS
- SIMPLE WIRE-SAVING UNITS
- WIRE-SAVING SYSTEMS
- MEASUREMENT SENSORS
- STATIC ELECTRICITY PREVENTION DEVICES
- LASER MARKERS
- PLC
- HUMAN MACHINE INTERFACES
- ENERGY CONSUMPTION VISUALIZATION COMPONENTS
- FA COMPONENTS
- MACHINE VISION SYSTEMS
- UV CURING SYSTEMS

PRECAUTIONS FOR PROPER USE

Refer to p.1458~ for general precautions and p.1499~ for information about laser beam.

• This catalog is a guide to select a suitable product. Be sure to read the instruction manual attached to the product prior to its use.



- Never use this product as a sensing device for personnel protection.
- In case of using sensing devices for personnel protection, use products which meet laws and standards, such as OSHA, ANSI or IEC etc., for personnel protection applicable in each region or country.

Cautions for laser beams



- These products are class 2 (LS-H□-A: Class 1) laser in compliance with IEC / JIS / GB standards and FDA* regulations. Do not look at the laser beam directly or through optical system such as a lens.
- The following label is attached to the product. Handle the product according to the instruction given on the warning label.

IEC / JIS / GB Class 2 type



(This product has warning labels attached and included in the packaging that are written in Japanese, English and Chinese for compliance with various standards.)

FDA Class 1 type



(This product has explanation labels attached and included in the packaging that are written in Japanese, English and Chinese for compliance with various standards.)

* This product complies with 21 CFR 1040.10 Laser Notice No. 50, dated July 26, 2001, issued by CDRH (Center for Devices and Radiological Health) under the FDA (Food and Drug Administration).

Safety standards for laser beam products

- A laser beam can harm human being's eyes, skin, etc., because of its high energy density. IEC has classified laser products according to the degree of hazard and the stipulated safety requirements. LS-H□(F) is classified as Class 2 laser. LS-H□(F)-A is classified as Class 1 laser.

Classification by IEC 60825-1

Classification	Description
Class 1	Lasers that are safe under reasonably foreseeable conditions of operation, including the use of optical instruments for intrabeam viewing.
Class 2	Lasers that emit visible radiation in the wavelength range from 400 nm to 700 nm where eye protection is normally afforded by aversion responses, including the blink reflex. This reaction may be expected to provide adequate protection under reasonably foreseeable conditions of operation including the use of optical instruments for intrabeam viewing.

Safe use of laser products

- For the purpose of preventing users from suffering injuries by laser products, IEC 60825-1 (Safety of laser products). Kindly check the standards before use.

Cautions when connecting amplifiers in cascade

- Refer to connecting conditions written below when connecting amplifiers in cascade.
- When amplifiers are installed, refer to "Cautions on communication function" and use communication function.

Connecting conditions

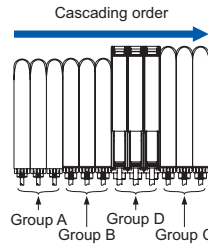

Group A	LS-401(P)(-C2), FX-301(P); Previous version unit (Note 1), FX-301G(P)/B(P)/H(P), FX-41□(P)
Group B	FX-301(P): Updated version unit (Note 1), FX-301(P)-C1, FX-305(P) (Note 2)
Group C	LS-403, DPS-400 series, SC-T1JA
Group D	FX-500 series

Notes: 1) The previous version unit is manufactured before June 2004. The updated version unit is manufactured after June 2004.
2) Be sure to install FX-305 behind FX-301.

Cautions on communication function

Copy function / channel bank function (when communicating)	Conditions when using SC-GU2-C	Interference prevention function
Each group should be cascaded in a lump. When group A, group B and group C are connected together in cascade, as for the products that are located between different groups, put the amplifier protection seal (FX-MB1 optional) on the amplifier communication window of each corresponding product. Interference prevention function cannot be used if amplifier protection seal is put on the amplifier communication window. Choose one from copy function / channel bank function (communication) or interference prevention function to be used.	[Group A] It cannot communicate with master. [Group B, Group C] They can communicate with master. When group B and group C are connected together in cascade, be sure that group B is located on the left side of group C.	Each group should be cascaded in a lump. When group A, group B and group C are connected together in cascade, refer to the connecting conditions for connecting. (Copy function cannot be used.)
When not using group A, copy function / channel bank function (communication) and interference prevention function can be used without putting on the amplifier protection seal. (Follow the connecting conditions when connecting.)		

Part description (Amplifier)

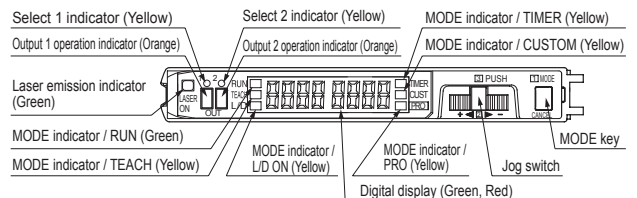

Spot-shape adjuster (Only for LS-H21□, LS-H22□)

- The diffuse reflective type LS-H21□ and LS-H22□ incorporate the spot-shape adjuster to adjust the shape of spots.

Spot-shape adjuster	Description
	Turn the spot-shape adjuster clockwise or counter-clockwise to adjust the spot shape at your desired detecting distance. However, if the adjuster is turned too far, it may be damaged.

PRECAUTIONS FOR PROPER USE

Refer to p.1458~ for general precautions and p.1499~ for information about laser beam.

Mounting

Amplifier

<How to mount the amplifier>

- ① Fit the rear part of the mounting section of the amplifier on a 35 mm 1.378 in width DIN rail.
- ② Press down the rear part of the mounting section of the unit on the 35 mm 1.378 in width DIN rail and fit the front part of the mounting section to the DIN rail.

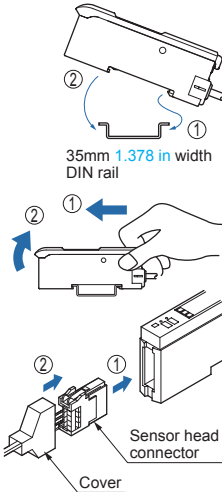

<How to remove the amplifier>

- ① Push the amplifier forward.
- ② Lift up the front part of the amplifier to remove it.

Note: Be careful. If the front part is lifted without pushing the amplifier forward, the hook on the rear portion of the mounting section is likely to break.

<How to mount the sensor head>

- ① Insert the sensor head connector into the inlet until it clicks.
- ② Fit the cover to the connector.

Sensor head

- The tightening torque should be 0.5 N·m or less.

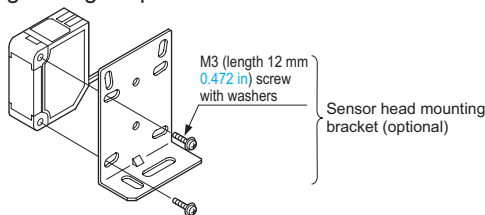

- When placing the sensor head horizontally or vertically, the reflector must also be positioned horizontally or vertically as shown in Fig. 1 below. If the sensor head is placed horizontally or vertically but the reflector is leaned as shown in Fig. 2 below, the reflection amount will decrease, which may cause unstable detection.

Fig. 1 Proper positioning

When placing the sensor head horizontally or vertically, the reflector shall also be positioned horizontally or vertically.

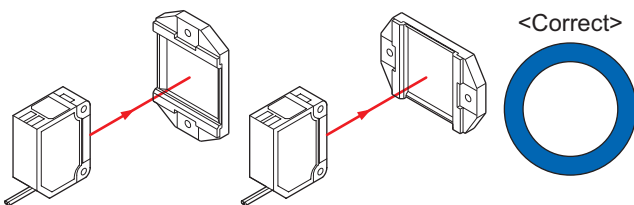
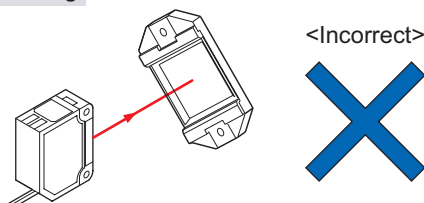

Fig. 2 Improper positioning

When placing the sensor head horizontally or vertically, but the reflector is leaned.



Lens attachment for line reflective type (LS-MR1)

- The lens attachment for line reflective type **LS-MR1** mounted in the long sensing range line reflective type **LS-H22** is removable. When **LS-H22** is used without **LS-MR1**, it will provide the equivalent performance to the long sensing range spot reflective type **LS-H21**. In addition, the optional **LS-MR1** can be attached to **LS-H21** to obtain the performance equivalent to **LS-H22**.
- Keep the lens clean of dust, dirt, water, oil, grease, etc.
- Do not apply any excessive force to **LS-MR1**. Such force may cause damage.

Removing method

- ① Insert a screwdriver into the fixing slot located at the top of sensor head.
- ② Tilt the screwdriver inserted in Step ① to remove **LS-MR1**.

Mounting method

- ① The size of upper fixing hook of **LS-MR1** is not same as the lower fixing hook. After identifying the upper and lower fixing hooks, insert **LS-MR1** upper fixing hook into the fixing slot at the top of sensor head and then insert **LS-MR1** lower fixing hook into the fixing slot at the bottom of sensor head.
- ② After mounting, check that **LS-MR1** is properly fixed to the sensor head.

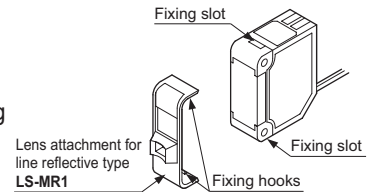

Wiring

- Make sure that the power supply is off while wiring.
- Verify that the supply voltage variation is within the rating.
- Take care that if a voltage exceeding the rated range is applied, or if an AC power supply is directly connected, the sensor may get burnt or damaged.
- Take care that short-circuit or wrong wiring of the load may burn or damage the sensor.
- Do not run the wires together with high-voltage lines or power lines or put them in the same raceway. This can cause malfunction due to induction.
- Ensure that an isolation transformer is utilized for the DC power supply. If an auto transformer is utilized, the main amplifier or power supply may be damaged.
- Make sure to use the optional quick-connection cable for the connection of the amplifier [connector type **LS-401(P)** / **LS-403**]. Extension up to total 100 m 328.084 ft is possible with 0.3 mm², or more, cable. However, in order to reduce noise, make the wiring as short as possible.

Others

- Do not use during the initial transient time (0.5 sec. approx.) after the power supply is switched on.
- Because the sensitivity is higher in U-LG mode than in other modes, it can be more easily affected by extraneous noise. Check the operating environment before use.
- These sensors are only for indoor use.
- Avoid dust, dirt, and steam.
- Take care that the product does not come in direct contact with water, oil, grease, or organic solvents, such as, thinner, etc.
- This sensor cannot be used in an environment containing inflammable or explosive gasses.
- Never disassemble or modify the sensor.

FIBER SENSORS

LASER SENSORS

PHOTO-ELECTRIC SENSORS

MICRO PHOTO-ELECTRIC SENSORS

AREA SENSORS

LIGHT CURTAINS / SAFETY COMPONENTS

PRESSURE / FLOW SENSORS

INDUCTIVE PROXIMITY SENSORS

PARTICULAR USE SENSORS

SENSOR OPTIONS

SIMPLE WIRE-SAVING UNITS

WIRE-SAVING SYSTEMS

MEASUREMENT SENSORS

STATIC ELECTRICITY PREVENTION DEVICES

LASER MARKERS

PLC

HUMAN MACHINE INTERFACES

ENERGY CONSUMPTION VISUALIZATION COMPONENTS

FA COMPONENTS

MACHINE VISION SYSTEMS

UV CURING SYSTEMS

Selection Guide

Amplifier Built-in

Amplifier-separated

LS-500

LS-400

FIBER SENSORS

LASER SENSORS

PHOTO-ELECTRIC SENSORS

MICRO PHOTO-ELECTRIC SENSORS

AREA SENSORS

LIGHT CURTAINS/SAFETY COMPONENTS

PRESSURE / FLOW SENSORS

INDUCTIVE PROXIMITY SENSORS

PARTICULAR USE SENSORS

SENSOR OPTIONS

SIMPLE WIRE-SAVING UNITS

WIRE-SAVING SYSTEMS

MEASUREMENT SENSORS

STATIC ELECTRICITY PREVENTION DEVICES

LASER MARKERS

PLC

HUMAN MACHINE INTERFACES

ENERGY CONSUMPTION VISUALIZATION COMPONENTS

FA COMPONENTS

MACHINE VISION SYSTEMS

UV CURING SYSTEMS

Selection Guide

Amplifier Built-in

Amplifier-separated

LS-500

LS-400

DIMENSIONS (Unit: mm in)

The CAD data in the dimensions can be downloaded from our website.

LS-H91(-A) LS-H91F(-A) Sensor head

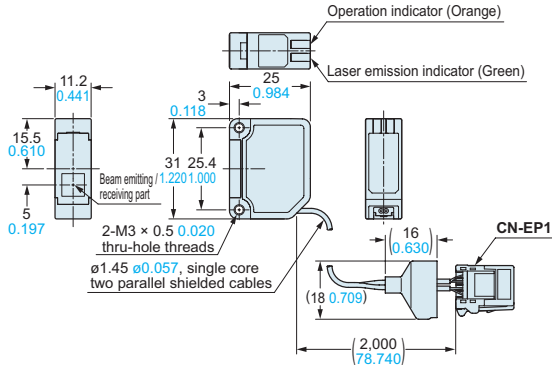

LS-H92 LS-H92F Sensor head

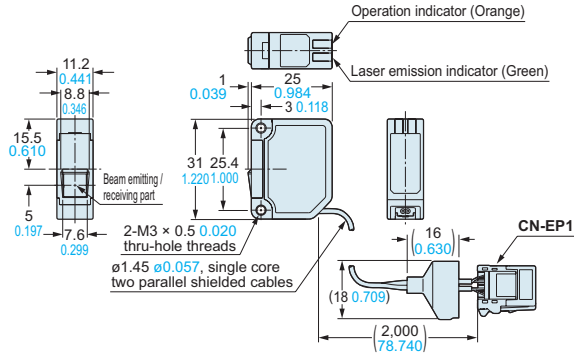

LS-H21(-A) LS-H21F(-A) Sensor head

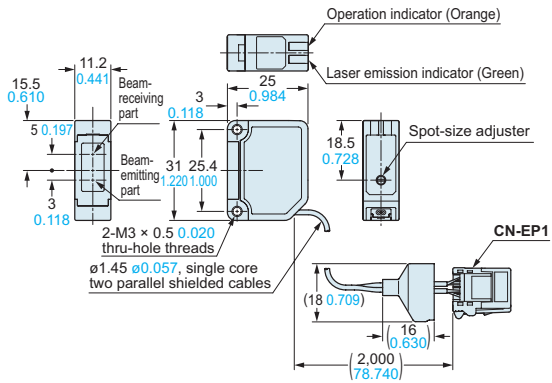

LS-H22 LS-H22F Sensor head

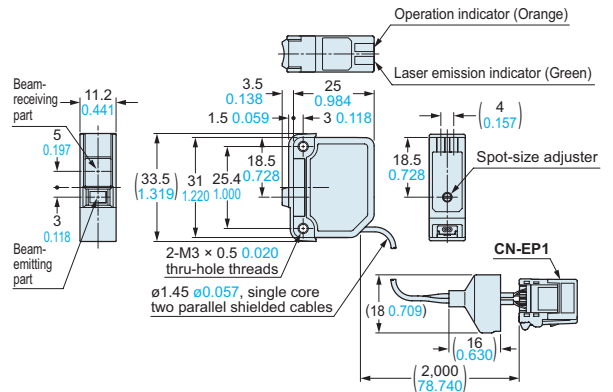

LS-401 LS-401P LS-403 Amplifier

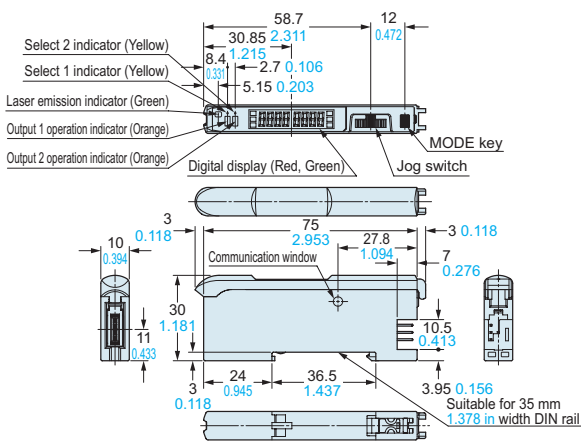

LS-401-C2 LS-401P-C2 Amplifier

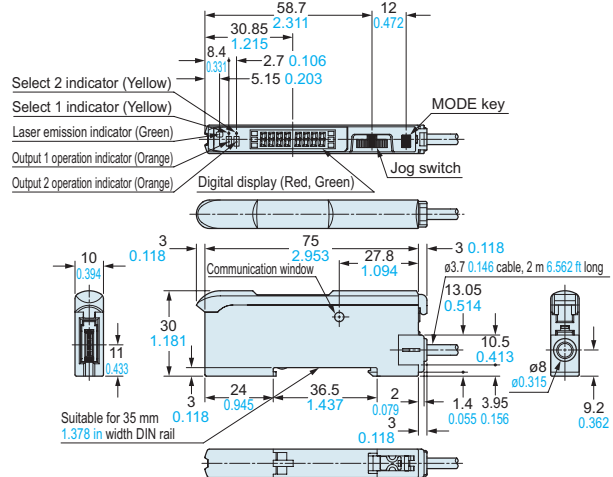

CN-74-C1 CN-74-C2 CN-74-C5 Main cable (Optional)

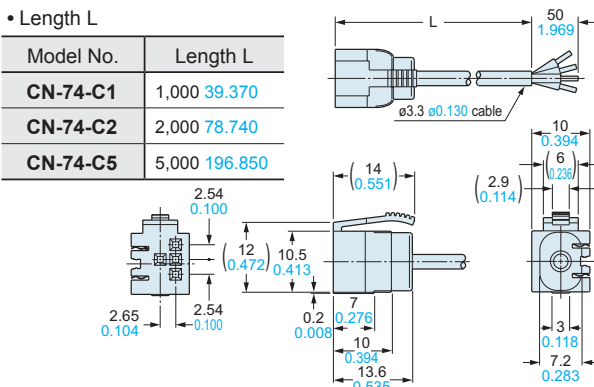

CN-72-C1 CN-72-C2 CN-72-C5 Sub cable (Optional)

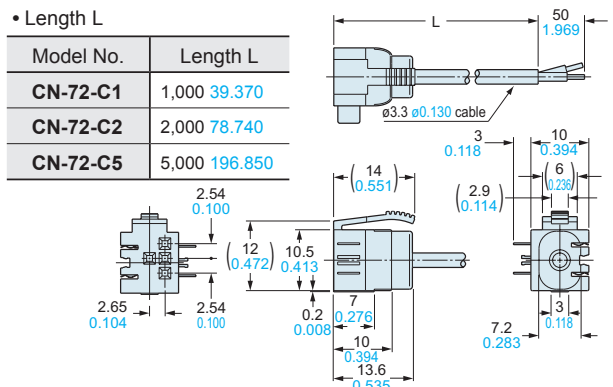

DIMENSIONS (Unit: mm in)

The CAD data in the dimensions can be downloaded from our website.

FIBER SENSORS

LASER SENSORS

PHOTO-ELECTRIC SENSORS

MICRO PHOTO-ELECTRIC SENSORS

AREA SENSORS

LIGHT CURTAINS / SAFETY COMPONENTS

PRESSURE / FLOW SENSORS

INDUCTIVE PROXIMITY SENSORS

PARTICULAR USE SENSORS

SENSOR OPTIONS

SIMPLE WIRE-SAVING UNITS

WIRE-SAVING SYSTEMS

MEASUREMENT SENSORS

STATIC ELECTRICITY PREVENTION DEVICES

LASER MARKERS

PLC

HUMAN MACHINE INTERFACES

ENERGY CONSUMPTION VISUALIZATION COMPONENTS

FA COMPONENTS

MACHINE VISION SYSTEMS

UV CURING SYSTEMS

Selection Guide

Amplifier Built-in

Amplifier-separated

LS-500

LS-400

MS-DIN-E End plate (Optional)

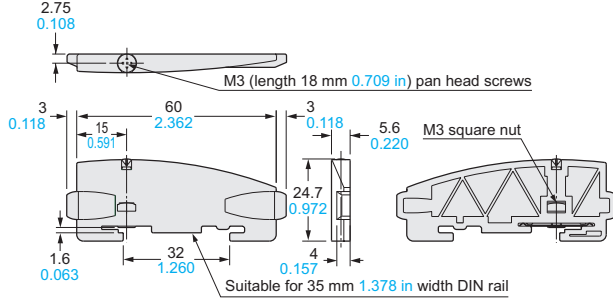

Material: Polycarbonate

RF-230 Reflector [Accessory for LS-H92(F)]

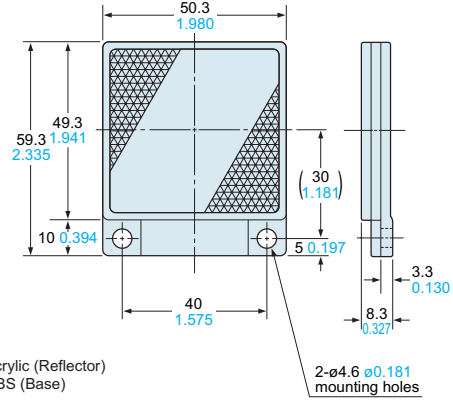

Material: Acrylic (Reflector)
ABS (Base)

RF-330 Reflector (Accessory for LS-H91□)

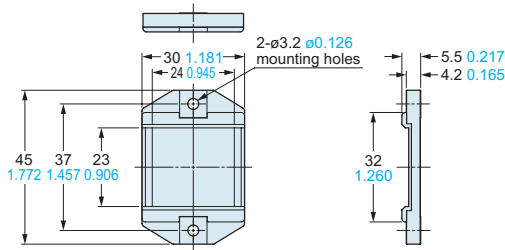

Material: Acrylic (Reflector)
ABS (Base)

RF-310 Reflector (Optional)

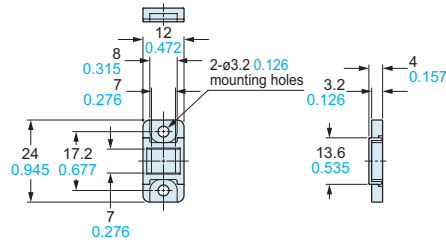

Material: Acrylic (Reflector)
ABS (Base)

RF-33 RF-31 Reflective tape (Optional)

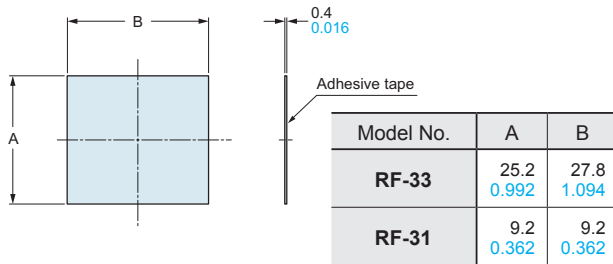

MS-DIN-2 Amplifier mounting bracket (Optional)

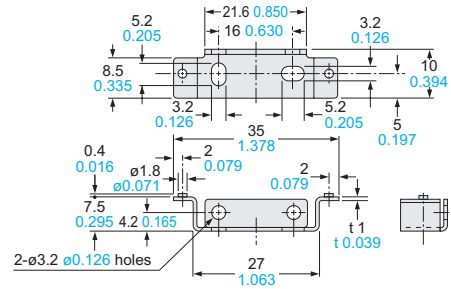

Material: Cold rolled carbon steel (SPCC)
(Uni-chrome plated)

MS-CX-1 Sensor head mounting bracket (Optional)

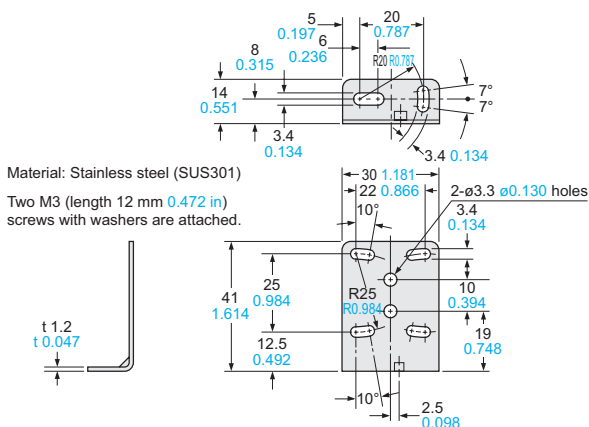

MS-CX-2 Sensor head mounting bracket (Optional)

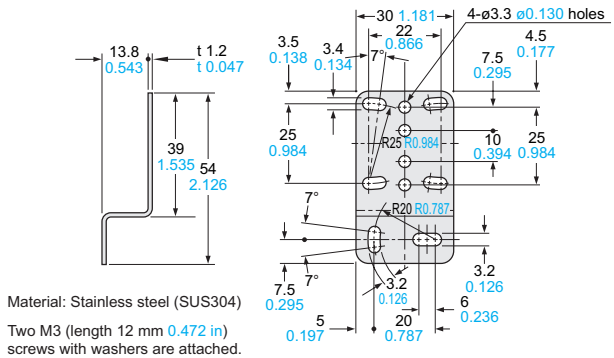

FIBER SENSORS

LASER SENSORS

PHOTO-ELECTRIC SENSORS

MICRO PHOTO-ELECTRIC SENSORS

AREA SENSORS

LIGHT CURTAINS/SAFETY COMPONENTS

PRESSURE / FLOW SENSORS

INDUCTIVE PROXIMITY SENSORS

PARTICULAR USE SENSORS

SENSOR OPTIONS

SIMPLE WIRE-SAVING UNITS

WIRE SAVING SYSTEMS

MEASUREMENT SENSORS

STATIC ELECTRICITY PREVENTION DEVICES

LASER MARKERS

PLC

HUMAN MACHINE INTERFACES

ENERGY CONSUMPTION VISUALIZATION COMPONENTS

FA COMPONENTS

MACHINE VISION SYSTEMS

UV CURING SYSTEMS

Selection Guide
Amplifier Built-in
Amplifier-separated

LS-500

LS-400

DIMENSIONS (Unit: mm in)

The CAD data in the dimensions can be downloaded from our website.

MS-CX-3 Sensor head mounting bracket (Optional)

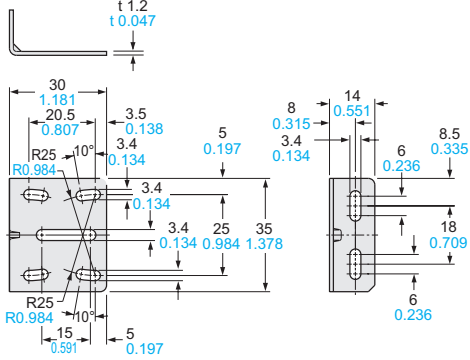

Material: Stainless steel (SUS304)
Two M3 (length 12 mm 0.472 in) screws with washers are attached.

MS-CX-4 Sensor head mounting bracket (Optional)

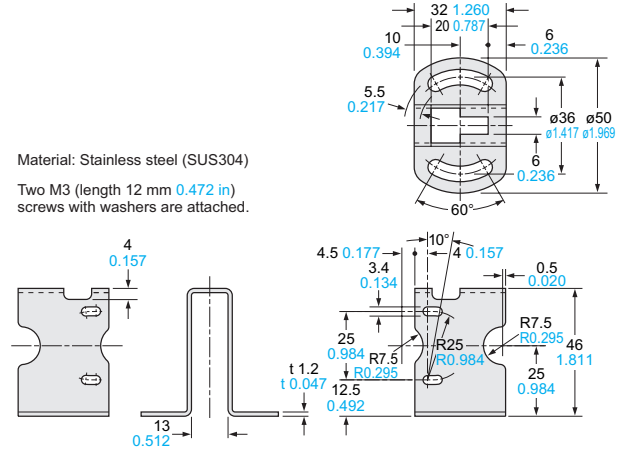

Material: Stainless steel (SUS304)
Two M3 (length 12 mm 0.472 in) screws with washers are attached.

MS-CX-11 Sensor mounting bracket for beam axis alignment (Optional)

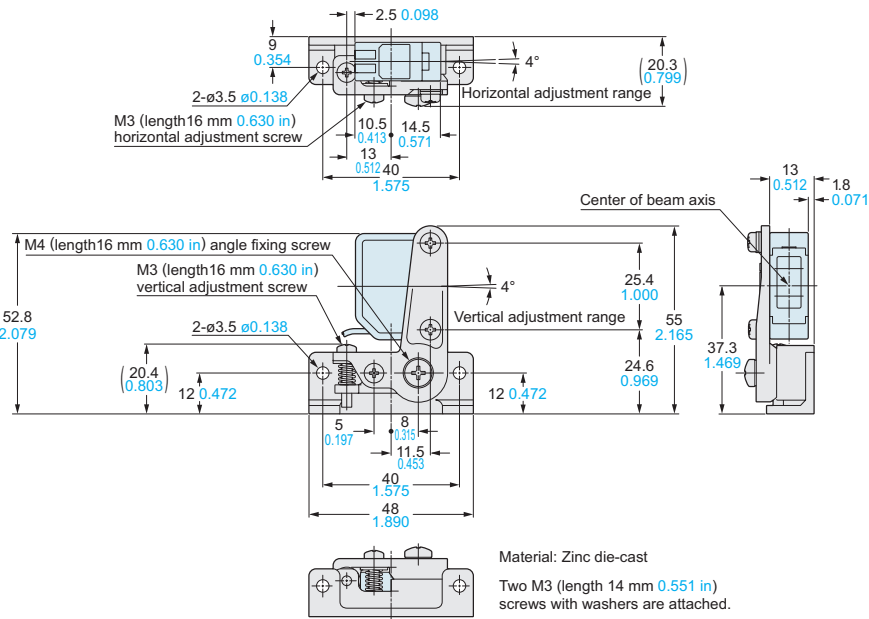

Material: Zinc die-cast
Two M3 (length 14 mm 0.551 in) screws with washers are attached.

MS-RF23 Reflector mounting bracket for RF-230 (Optional)

Assembly dimensions

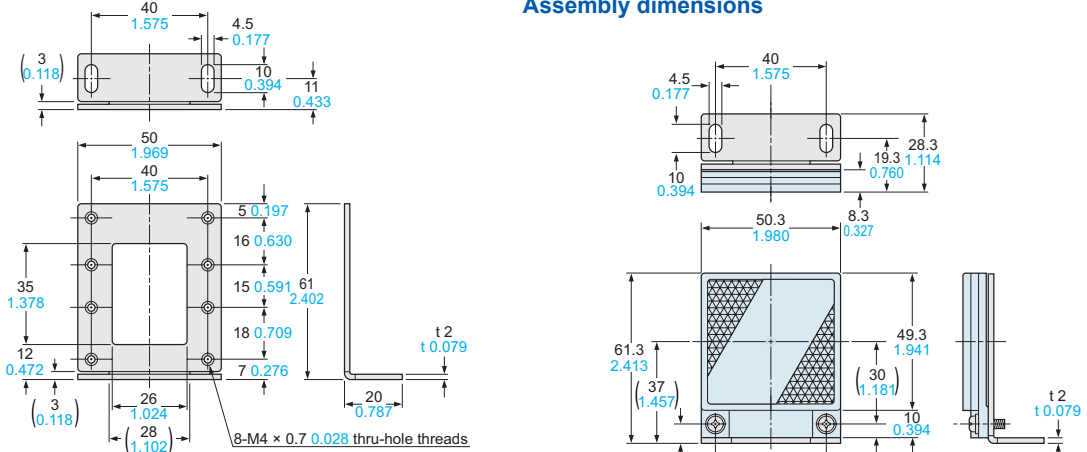

Material: Cold rolled carbon steel (SPCC) (Uni-chrome plated)
Two M4 (length 10 mm 0.394 in) screws with washers are attached.