

Thank you very much for purchasing Panasonic products. Please read this Instruction Manual carefully and thoroughly for the correct and optimum use of this product. Kindly keep this manual in a convenient place for quick reference.

WARNING

- Never use this product as a sensing device for personnel protection.
- In case of using sensing devices for personnel protection, use products which meet laws or standards, such as OSHA, ANSI or IEC etc., for personnel protection applicable in each region or country.
- Use of control or adjustment or performance of procedures other than those specified in this instruction manual may result in hazardous radiation expose.

For details of the setting contents or setting procedure, refer to 'LS series PRO mode operation guide' in 'Panasonic Industrial Devices SUNX website (<http://panasonic.net/id/pidsx/global>)'.

1 PART DESCRIPTION

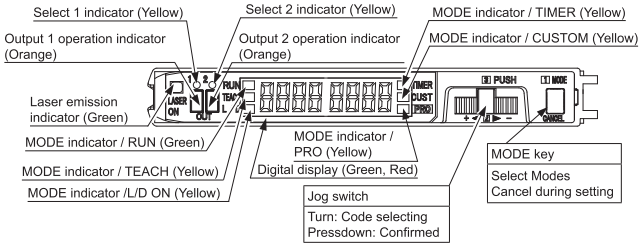

2 MOUNTING

How to mount the amplifier

1. Fit the rear part of the mounting section of the amplifier on a DIN rail.
2. Press down the rear part of the mounting section of the unit on the DIN rail and fit the front part of the mounting section to the DIN rail.

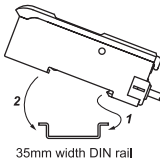

How to remove the amplifier

1. Push the amplifier forward. (Note)
2. Lift up the front part of the amplifier to remove it.

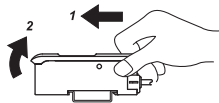

Note: Take care that if the front part is lifted without pushing the amplifier forward, the hook on the rear portion of the mounting section is likely to break.

How to mount the sensor head

1. Insert the sensor head connector into the inlet until it clicks.
2. Fit the cover to the connector.

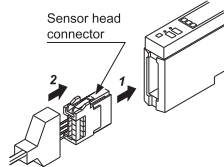

3 CASCADING CONNECTOR TYPE LS-401(P)

- For mounting and removing the amplifier, refer to '2 MOUNTING'.
- Up to maximum 15 amplifiers can be added. (total 16 amplifiers connected in cascade.)
- When this product is used with the digital fiber amplifier, be sure to place this product to the left most position. (When viewed from the connector side) In case this product is not placed to the leftmost position, this product may not operate properly.

Cascading method

1. Mount the amplifiers, one by one, on the 35mm width DIN rail.
2. Slide the amplifiers next to each other, and connect the quick-connection cables.
3. Mount the optional end plates (MS-DIN-E) at both the ends to hold the amplifiers between their flat sides.
4. Tighten the screws to fix the end plates.

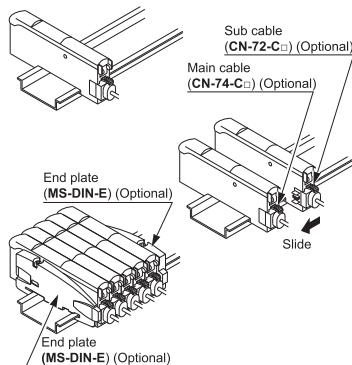

Dismantling method

1. Loosen the screws of the end plates.
2. Remove the end plates.
3. Slide the amplifiers and remove them one by one.

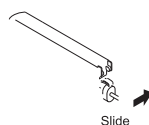

4 I/O CIRCUIT DIAGRAM

• NPN output type

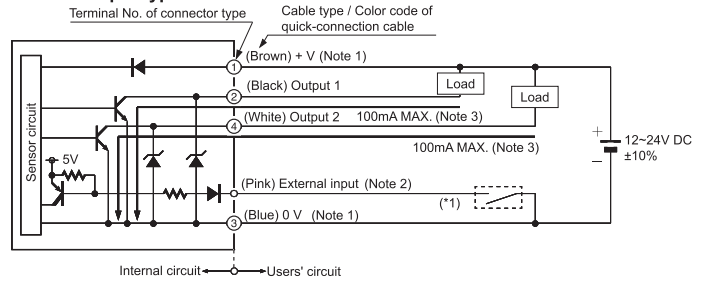

• PNP output type

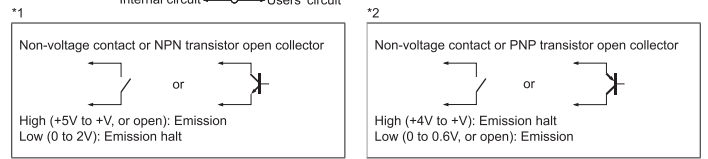
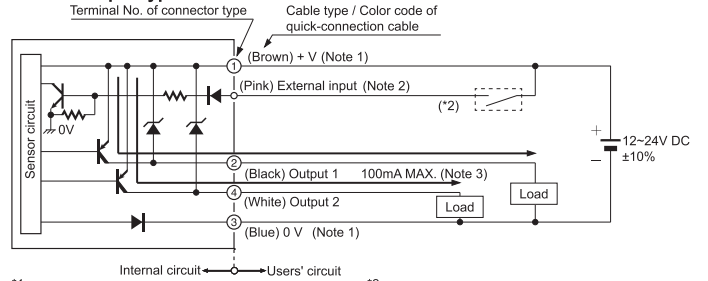

Notes :1) The quick-connection sub cable does not have +V (brown) and 0V (blue). The power is supplied from the connector of the main cable.
2) External input is not incorporated with the connector type LS-401(P).
3) 50mA max. if 5 to 8 units are connected in cascade, and 25mA max. if 9 to 16 units are connected in cascade.

Layout of terminals of connector type LS-401 (P)

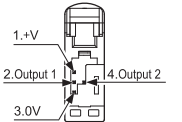

5 EXTERNAL INPUT [only for LS-401(P)-C2]

- When 'emission halt', 'limit teaching' or 'full-auto teaching' is set, the time chart is as follows.

Time chart

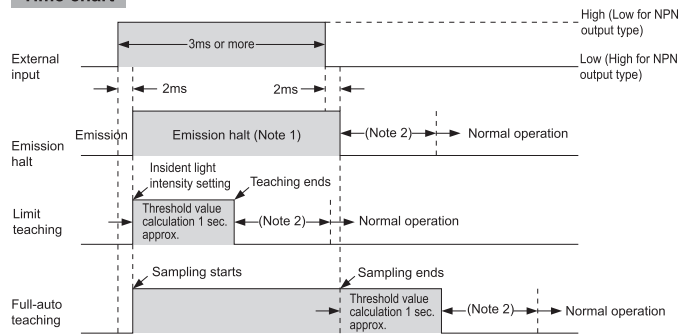

Notes :1) In the emission halt state, since the incident light intensity is judged as 0, the signal is output when the emission halt is confirmed (the trailing differential mode is selected) or the emission halt is canceled (the rising differential mode is selected) in the differential mode.
2) The output operation only for response time is not fixed.

6 OPERATION PROCEDURE

- Be sure to set each item after selecting the output 1 or the output 2.
- The items that can be set in the output 1 and the output 2 respectively are only 1. Threshold value, 2. Output operation, 3. Timer operation and Timer period, and 4. Detection mode. The items other than those are common. (However, in case of setting with the direct code, a combination of the output 1/2 can be set only for output operation. The items other than output operation are valid only for the output 1.)

• System of basic operation

The amplifier of LS-400 series features and settings are generally classified into two main modes; the 'NAVI' mode for items and settings that are frequently re-configured, and the 'PRO' mode that contains more detailed settings.

● Procedures for switching the NAVI mode

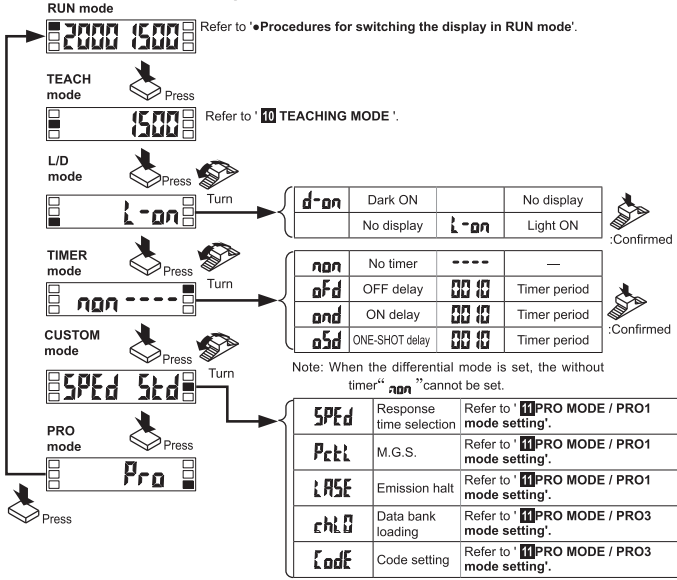

● Procedures for switching the display in RUN mode

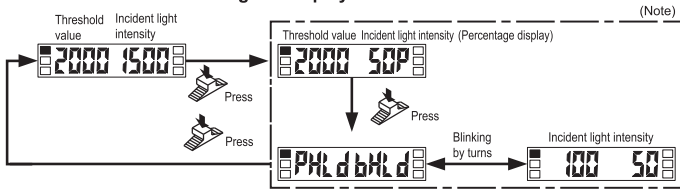

*Displayed only in Window comparator mode or Hysteresis mode and Differential mode.

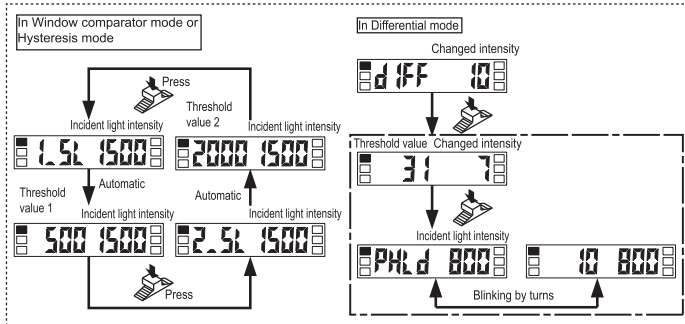

Note: Can be displayed if the display switching "d-L" is set to "OFF" to enable the display switching in PRO2 of PRO mode.

7 THRESHOLD VALUE FINE ADJUSTMENT FUNCTION

- The threshold can be fine-adjusted when the MODE indicator / RUN (green) lights up.
- Turn the jog switch to either '+' (left) or '-' (right) to increase / decrease the threshold value.
- The value is automatically memorized unless TEACH mode is selected after the adjustment or any switch operation is not carried out within a certain period of time.

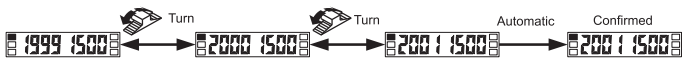

※: When you turn the jog switch to '+' or '-' in Window comparator mode or Hysteresis mode, the threshold will increase or decrease after the output 1 "1.5L" or the output 2 "2.5L" is displayed.

If you turn the jog switch to '+' when the output 1 "1.5L" is displayed, the following will be displayed.



8 OUTPUT CHANNEL SWITCHING

- Press the MODE key for more than 2 seconds when in NAVI mode. If Output 1 has been selected, the Select 1 indicator (yellow) lights up. If the output 2 is being selected, the Select 2 indicator (yellow) lights up.

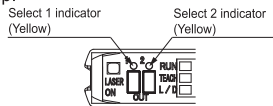

9 KEYLOCK FUNCTION

- If the jog switch and MODE key are press down simultaneously for more than 3 seconds when the MODE indicator / RUN (green) is on, the key operation is locked. Press down for more than 3 seconds again to unlock the key.



10 TEACHING MODE

When teaching in Window comparator mode or Hysteresis mode, a setting has to be made in PRO6 beforehand. In case of 1-level teaching, a shift value (the initial value is 100 digit or 15%) has to be set as well. teaching.

In case of 2-level teaching

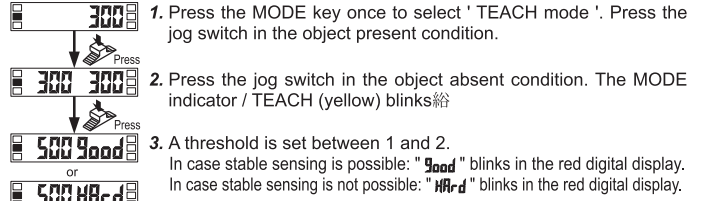

In case of Limit-teaching

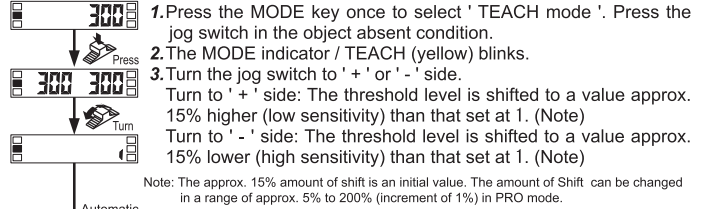

In case of Full-auto teaching

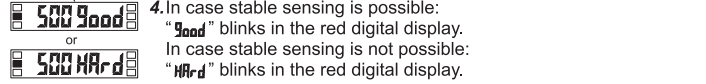

In case of 1-level teaching in Window comparator mode or Hysteresis mode

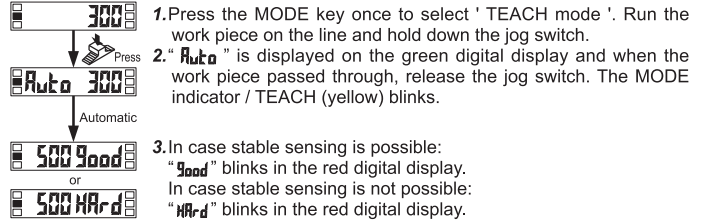

- This is the method to set the shift value to the desired value and set the threshold range by using the single-point teaching.

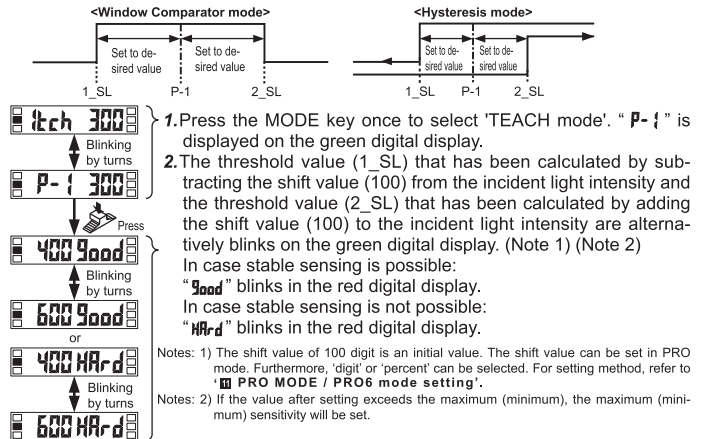

In case of 2-level teaching in Window Comparator mode or Hysteresis mode

- This method is to set the threshold range by using the 2-point teaching (P-1, P-2).

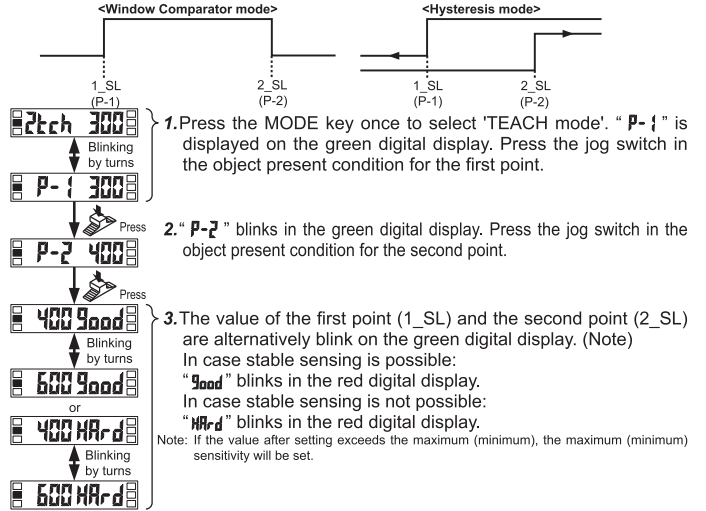

In case of 3-level teaching in Window comparator mode or Hysteresis mode

- This is the method to set the threshold range by setting the threshold (1_SL) of the mid-point between 'A' and 'B' and the threshold (2_SL) of the mid-point between 'B' and 'C', using the 3-point teaching (P-1, P-2, P-3).
- After teaching, P-1, P-2 and P-3 will be automatically relocated in ascending order: i.e. the lowest value is placed in 'A', the second lowest in 'B' and the highest in 'C'.

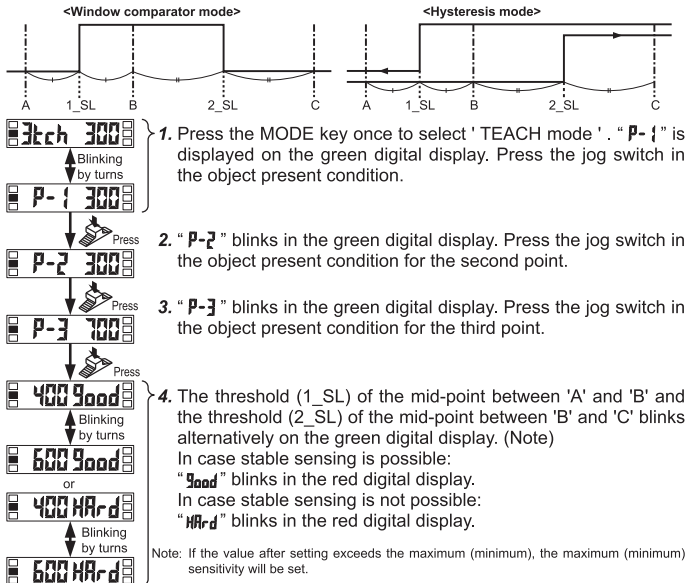

Span adjustment in Differential mode

- If Differential mode is selected when in PRO6 mode, ONE-SHOT timer (10ms) at the max. sensitivity is automatically set. Move to the rising differential mode, or the trailing differential mode in the PRO6 mode, and press the jog switch to confirm the setting.

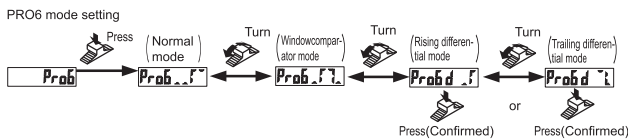

- The span adjustment in the differential mode can be set as follows in the TEACH mode. The value is automatically memorized unless L/D mode is selected after the adjustment or any switch operation is not carried out within a certain period of time.
- The threshold can be set by using the threshold value fine adjustment function. For details, refer to 'THRESHOLD VALUE FINE ADJUSTMENT FUNCTION'.

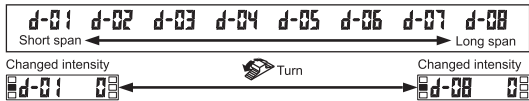

11 PRO MODE

- When MODE indicator / PRO (yellow) lights up, PRO mode can be set.



PRO1 mode setting

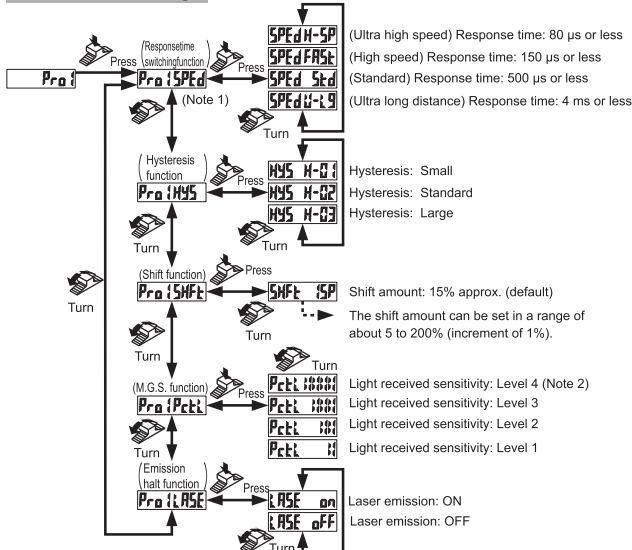

Notes: 1) Display for laser amount can show the digit of max. 4,000 digits if 'H-SP' for ultra high speed or 'FASt' for high speed is selected in the response time switching function 'SPeD', but will display the digit of max. 9,999 digits if 'Std' for standard or 'U-Lg' for ultra long distance is selected.
2) This can be selected only if 'SPeD' for ultra long distance (response time of 4ms or less) is selected in the response time switching function 'U-Lg'.

PRO2 mode setting

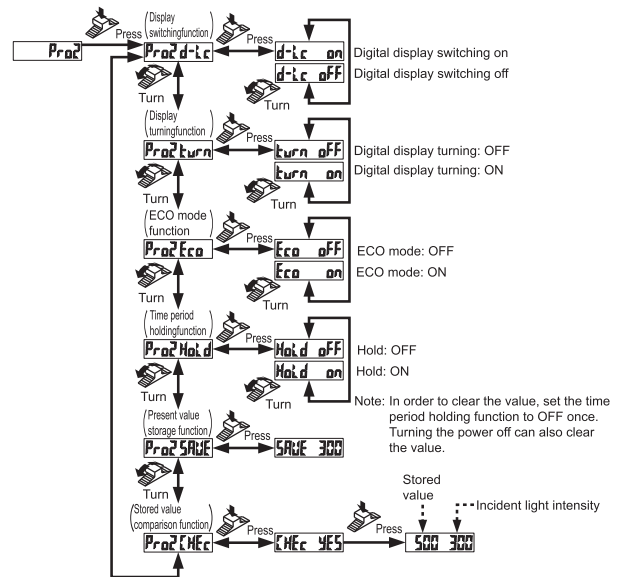

PRO3 mode setting

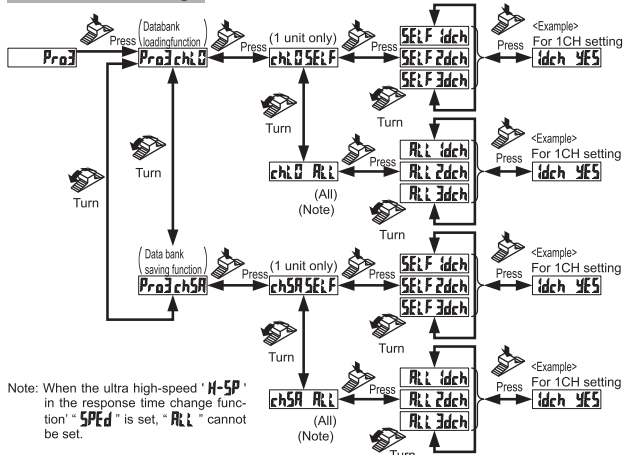

PRO4 mode setting

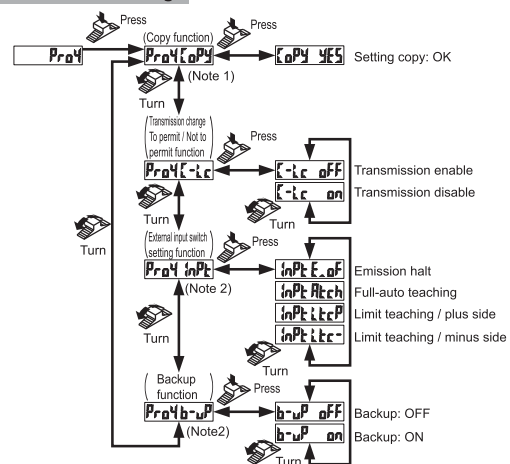

Notes: 1) When the ultra high-speed 'H-SP' in the response time change function 'SPeD' is set, the copy function cannot be used.
2) This indication is not shown on the connector type LS-401(P).

PRO5 mode setting

The 0-ADJ setting function in this product was removed from production starting May, 2005.

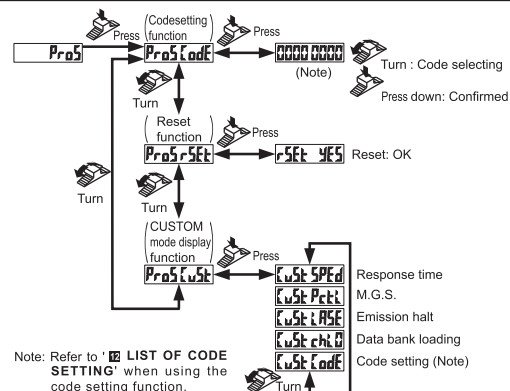

PRO6 mode setting

Output 1

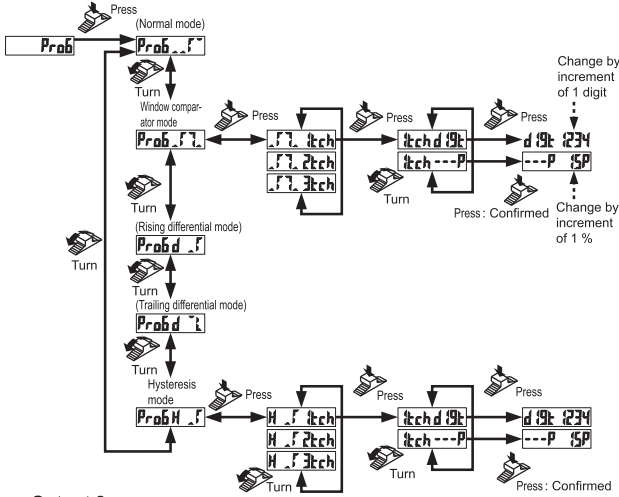

Output 2

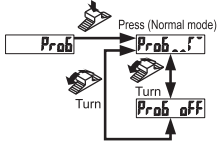

12 LIST OF CODE SETTING

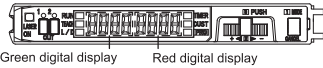

Green digital display

First digit		Second digit		Third digit		Fourth digit	
Direct code	Output operation (Output 1, Output 2)	Direct code	Timer operation	Direct code	Response time	Direct code	M.G.S.
0	L-ON · L-ON	0	OFF	0	STD	0	Level 3
1	L-ON · D-ON	1	On delay	1	H-SP	1	Level 2
2	D-ON · L-ON	2	Off delay	2	FAST	2	Level 1
3	D-ON · D-ON	3	One-shot Timer	3	U-LG	3	Level 4
4	—	4	—	4	—	4	—
5	—	5	—	5	—	5	—
6	—	6	—	6	—	6	—
7	—	7	—	7	—	7	—
8	—	8	—	8	—	8	—
9	—	9	—	9	—	9	—

Red digital display

First digit			Second digit (Note)			Third digit		Fourth digit	
Direct code	Hysteresis	Copy lock	Direct code	External input	Backup	Direct code	CUSTOM	Direct code	Detection mode
0	H-02	OFF	0	Emission halt	ON	0	Response time	0	Normal 2 Output
1	H-02	ON	1	Emission halt	OFF	1	M.G.S.	1	Window comparator
2	H-03	OFF	2	Auto teaching	ON	2	Emission halt	2	Rising differential
3	H-03	ON	3	Auto teaching	OFF	3	Data bank loading	3	Trailing differential
4	H-01	OFF	4	Limit +	ON	4	D code	4	Hysteresis
5	H-01	ON	5	Limit +	OFF	5	—	5	Output 2 OFF
6	—	—	6	Limit -	ON	6	—	6	—
7	—	—	7	Limit -	OFF	7	—	7	—
8	—	—	8	—	—	8	—	8	—
9	—	—	9	—	—	9	—	9	—

█: The highlighted line indicates the default code (factory setting).
Note: Connector type LS-401(P) shows only "0".

13 ERROR DISPLAY

- Take the following actions in case of errors.

Display	Description of error	Action
E-1	Overcurrent has been applied due to short-circuited load.	Turn off the power supply and check the load.
E-4	Disconnection error of sensor head	Check the connection of sensor head.
E-5	Transmission error during connection.	Verify that there is no loose or clearance between amplifiers.

14 OPTICAL COMMUNICATION

- When the collective data bank load / save function or copy function is used via optical communication, loading / saving or copy of the setting can be carried out only to the amplifiers (sub units) connected on the right side of the amplifier (main unit), as shown in the figure below. However, if the amplifier (sub unit) is being connected (the indicator blinks), PRO mode is being set or the transmission enable / disable function is set to 'disable', loading / saving or copy is not carried out. Furthermore, the sensing operation stops during optical communication.

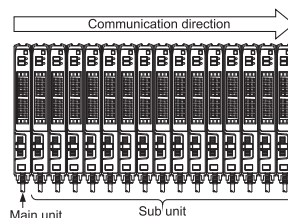

15 SPECIFICATIONS

Type	Connector type		Cable type
Model No.	NPN Output	LS-401	LS-401-C2
	PNP Output	LS-401P	LS-401P-C2
Supply voltage	12 to 24V DC±10%		Ripple P-P 10% or less
Power consumption	Normal operation: 950mW or less (current consumption 40mA or less at 24V supply voltage) ECO mode: 780mW or less (current consumption 33mA or less at 24V supply voltage)		
Output (Output 1, Output 2)	<NPN output type> NPN open-collector transistor • Maximum sink current: 100mA (Note 1) • Applied voltage: 30V DC or less (between output and 0V) • Residual voltage: 1.5V or less [at 100mA (Note 1) sink current]		<PNP output type> PNP open-collector transistor • Maximum source current: 100mA (Note 1) • Applied voltage: 30V DC or less (between output and +V) • Residual voltage: 1.5V or less [at 100mA (Note 1) source current]
	Output operation	Light-ON or Dark-ON, selectable with jog switch	
Short-circuit protection	Incorporated		
External input (Note 2)	<NPN output type> NPN non-contact input • Signal condition High: +5 to +4V DC or open Low: 0 to 2V DC (source current 0.5mA) • Input impedance: 10kΩapprox.		<PNP output type> PNP non-contact input • Signal condition High: +4 to +1V DC (sink current 3mA or less) Low: 0 to 0.6V DC, or open • Input impedance: 10kΩapprox.
	Response time	H-SP: 80µs or less, FAST: 150µs or less, STD: 500µs or less, U-LG: 4ms or less, selectable with jog switch	
Digital display	4 digit (green) + 4 digit (red) LED display		
Sensitivity setting	Normal mode	2-level teaching / Limit teaching / Full-auto teaching / Manual adjustment	
	Window comparator mode	Teaching (1, 2, 3 level) / Manual adjustment	
	Hysteresis mode	Teaching (1, 2, 3 level) / Manual adjustment	
	Differential mode	8-level settings	
Fine sensitivity adjustment function	Incorporated		
Timer function	Incorporated with variable ON-delay/OFF-delay/ONE-SHOT timer, switchable either effective or ineffective (Timer period: 1 to 9999ms approx.)		
Interference prevention function	Incorporated [Up to four sensor heads can be mounted adjacently (However, in H-SP mode, the interference prevention function cannot be operated)] (Note 3)		
Ambient temperature	-10 to +55°C (If 4 to 7 units are mounted closely: -10 to +50°C, if 8 to 16 units are mounted closely: -10 to +45°C) (No dew condensation or icing allowed), Storage: -20 to +70°C		
Ambient humidity	35 to 85% RH, Storage: 35 to 85% RH		
Material	Enclosure: Heat-resistant ABS, Transparent cover: Polycarbonate, Mode key switch: Acrylic, Jog switch: ABS		
Weight	Approx.15g		Approx.65g

- Notes: 1) 50mA max. if 5 to 8 units are connected in cascade, and 25mA max. if 9 to 16 units are connected in cascade.
2) External input is not incorporated with the connector type LS-401(P).
3) After H-SP mode was changed to other mode, when the interference prevention function, the collective data bank load/save function or the copy function is used, turn the power supply on again.
4) The cable is not supplied as an accessory for connector type LS-401(P). Be sure to use the optional quick-connection cables given below.
Main cable (4-core):CN-74-C1(cable length 1m), CN-74-C2(cable length 2m), CN-74-C5(cable length 5m)
Sub cable (2-core):CN-72-C1(cable length 1m), CN-72-C2(cable length 2m), CN-72-C5(cable length 2m)

16 CAUTIONS

- This product has been developed / produced for industrial use only.
- Make sure that the power supply is off while wiring.
- Verify that the supply voltage variation is within the rating.
- Take care that if a voltage exceeding the rated range is applied, or if an AC power supply is directly connected, the sensor may get burnt or damaged.
- In case noise generating equipment (switching regulator, inverter motor, etc.) is used in the vicinity of this product, connect the frame ground (F.G.) terminal of the equipment to an actual ground.
- The ultra long distance (U-LG) mode is more likely to be affected by extraneous noise since the sensitivity of that is higher than the other modes. Make sure to check the environment before use.
- If power is supplied from a commercial switching regulator, ensure that the frame ground (F.G.) terminal of the power supply is connected to an actual ground.
- Do not use during the initial transient time (0.5 sec.) after the power supply is switched on.
- Take care that short-circuit of the load or wrong wiring may burn or damage the sensor.
- Do not run the wires together with high-voltage lines or power lines or put them in the same raceway. This can cause malfunction due to induction.
- Make sure to use the optional quick-connection cable for the connector type LS-401(P).
- Extension up to total 100m is possible with 0.3mm², or more, cable. However, in order to reduce noise, make the wiring as short as possible. However, the extension of a power supply line and the output line of less than 10m is acceptable in case using this product as conforming to S-mark.
- This sensor is suitable for indoor use only.
- Avoid dust, dirt, and steam.
- Take care that the product does not come in contact with water, oil, grease, or organic solvents, such as, thinner, etc.
- This sensor cannot be used in an environment containing inflammable or explosive gases.
- Never disassemble or modify the sensor.

17 INTENDED PRODUCTS FOR CE MARKING

- The models listed under '15 SPECIFICATIONS' come with CE Marking. As for all other models, please contact our office.
- Contact information for CE**
<Until June 30 ,2013>
Panasonic Industrial Devices Sales Central Europe AG
Rudolf-Diesel-Ring 2, D-83607 Holzkirchen, Germany
<From July 1 ,2013>
Panasonic Marketing Europe GmbH Panasonic Testing Center
Winsbergring 15, 22525 Hamburg,Germany

Panasonic Industrial Devices SUNX Co., Ltd.

<http://panasonic.net/id/pidsx/global>

Overseas Sales Division (Head Office)
2431-1 Ushiyama-cho, Kasugai-shi, Aichi, 486-0901, Japan
Phone: +81-568-33-7861 FAX: +81-568-33-8591

About our sale network, please visit our website.

PRINTED IN JAPAN

© Panasonic Industrial Devices SUNX Co., Ltd. 2012